



NOTICE OF REGULAR MEETING OF THE GUADALUPE TOWN COUNCIL

THURSDAY, SEPTEMBER 14, 2023

6:00 P.M.

GUADALUPE TOWN HALL
9241 SOUTH AVENIDA DEL YAQUI, COUNCIL CHAMBERS
GUADALUPE, ARIZONA

Valerie Molina
Mayor

Ricardo Vital
Vice Mayor

Mary Bravo
Councilmember

Esteban F. V. Fuerte
Councilmember

Elvira Osuna
Councilmember

Joe Sánchez
Councilmember

Anita Cota Soto
Councilmember

Agendas/Minutes:
www.guadalupeaz.org

Town Council Chambers
9241 S. Avenida del Yaqui
Guadalupe, AZ 85283
Phone: (480) 730-3080
Fax: (480)-505-5368

Pursuant to A.R.S. 38-431.02, notice is hereby given to the members of the Guadalupe Town Council and to the public that the Guadalupe Town Council will hold a meeting, open to the public, on Thursday, September 14, 2023, at 6:00 P.M., at Guadalupe Town Hall, 9241 South Avenida del Yaqui, Council Chambers, Guadalupe, Arizona. Meetings are streamed live on Town of Guadalupe Facebook page at <https://www.facebook.com/guadalupeaz.org>.

AGENDA

A. CALL TO ORDER

B. ROLL CALL

C. INVOCATION/PLEDGE OF ALLEGIANCE

D. APPROVAL OF MINUTES

1. Approval of the August 23, 2023, Town Council Study Session Meeting Minutes.

E. CALL TO THE PUBLIC: An opportunity is provided to the public to address the Council on items that are not on the agenda or included on the consent agenda. A total of 3 minutes will be provided for the Call to the Audience agenda item unless the Council requests an exception to this limit. Please note that those wishing to comment on agenda items posted for action will be provided the opportunity at the time the item is heard.

F. MAYOR and COUNCIL PRESENTATION: None.

G. DISCUSSION AND POSSIBLE ACTION ITEMS:

1. **MARICOPA COUNTY SHERIFF'S OFFICE UPDATE:** Council will receive an update from representatives from the Maricopa County Sheriff's Office regarding public safety in the Town of Guadalupe. Council may provide direction to the Town Manager / Clerk. *(there is no material for this item)*

2. **ARIZONA DEPARTMENT OF ENVIRONMENTAL QUALITY (ADEQ) MUNICIPAL SEPARATE STORM SEWER SYSTEM (MS4) GENERAL PERMIT AND AUDIT COMPLIANCE STATUS REPORT:** Council will receive an update from staff and Town Engineer, Dibble Engineering, regarding engineering services to complete the Municipal Separate Storm Sewer System (MS4) General Permit and ADEQ Audit to bring the Town of Guadalupe into compliance with stormwater management regulations as required. Council may provide direction to the Town Manager / Clerk.



Valerie Molina
Mayor

Ricardo Vital
Vice Mayor

Mary Bravo
Councilmember

Esteban F. V. Fuerte
Councilmember

Elvira Osuna
Councilmember

Joe Sánchez
Councilmember

Anita Cota Soto
Councilmember

Agendas/Minutes:
www.guadalupeaz.org

Town Council Chambers
9241 S. Avenida del Yaqui
Guadalupe, AZ 85283
Phone: (480) 730-3080
Fax: (480)-505-5368

3. NEIGHBORHOOD STREET LIGHTING IMPROVEMENT PROJECT REPORT: Council will receive a report from staff and Town Engineer, Dibble Engineering, regarding the recently completed street light project where 14 new streetlights were installed on Calle Batoua, Calle Biehn, Calle Carlos, Calle Tomi & Calle Guadalupe. The goal of the project is to improve neighborhood lighting and safety and serve as a pilot program for improving neighborhood lighting throughout Guadalupe. Council may provide direction to the Town Manager / Clerk.

4. FISCAL YEAR 2022/2023 TOWN GENERAL FUND YEAR END REVIEW: Council will receive a review of the Fiscal Year 2022/23 General Fund budget performance. The presentation will include an overview of the Town FY2022/23 General Fund \$6.3M year-end fund balance and the fiscal impact of two unanticipated project expenditures totaling an estimated \$255,187. Council may provide direction to the Town Manager / Clerk.

5. HIGHLINE CANAL RECREATIONAL PATH LIGHTING REPLACEMENT PROJECT – ARIZONA DEPARTMENT OF TRANSPORTATION PAYMENT: Council will consider and may take action to approve a payment in the amount of \$987,163, as invoiced, to the Arizona Department of Transportation for the Highline Canal Recreational Path Lighting Replacement Project, in accordance with Intergovernmental Agreement (IGA) C2022-48 between the State of Arizona through its Department of Transportation and the Town of Guadalupe, approved November 10, 2022. The estimated total project cost is \$1,488,987 and is funded through a \$501,824 Federal Community Project grant, a \$679,500 SRP neighborhood aesthetic fund allocation, and \$307,663 from Town Capital funds. Construction is scheduled to begin in February 2024. Approval of the payment authorizes the Mayor, or designee, to sign all necessary documents in furtherance of this project. Council may provide direction to the Town Manager / Clerk.

H. TOWN MANAGER/CLERK'S COMMENTS

I. COUNCILMEMBERS' COMMENTS

J. ADJOURNMENT



September 8, 2023

To: The Honorable Mayor and Town Council

From: Jeff Kulaga, Town Manager / Clerk

RE: **September 14, 2023, Town Council Regular Meeting Information Report**

The purpose of this report is to provide brief information regarding each agenda item.

Agenda Items:

D1. AUGUST 23, 2023, STUDY SESSION MEETING MINUTES (PAGES 5 – 9)

G1. MARICOPA COUNTY SHERIFF'S OFFICE UPDATE (NO MATERIAL): Council will receive an update from representatives from the Maricopa County Sheriff's Office regarding public safety in the Town of Guadalupe. Council may provide direction to the Town Manager / Clerk.

G2. MUNICIPAL SEPARATE STORM SEWER SYSTEM (MS4) PROGRAM UPDATE (PAGES 10 – 22): Council will receive an update from Town Engineer, Dibble Engineering, regarding the Municipal Separate Storm Sewer System (MS4) Program. The MS4 program is administered by ADEQ with the role of regulating storm water management practices in Town. The goal of the MS4 is to prevent harmful pollutants from entering the Town's Storm Sewer System, which in turn will prevent them from entering protected waterways should a discharge occur. A recent audit by ADEQ of the Town's MS4 program identified components that needed updating and/or development.

In April 2023, The Town contracted with Dibble Engineering to complete the Municipal Separate Storm Sewer System (MS4) General Permit to bring the Town of Guadalupe into compliance with stormwater management regulations as required the Arizona Department of Environmental Quality (ADEQ). The approved contract amount is \$38,355 and is funded through the FY23 Town General Fund Town Manager cost center.

As background, ADEQ annually requires the submittal of an MS4 compliance report regarding the discharge and management of stormwaters by all Arizona counties and municipalities. Should the annual report be approved, ADEQ permits the public entity to operate municipal separate storm sewer systems (MS4s).

The permit authorizes the discharge of stormwater to protected surface waters from Small MS4s, which may include:

- A city, town or county located fully or partially within an urbanized area as determined by the latest Decennial Census by the Bureau of Census
- State, federal and other publicly owned properties discharge stormwater.
- Other areas designated by ADEQ.

The permit requires the development of a stormwater management program. The permittees are required to follow six minimum control measures that must be built into their program including:

1. Public Education and Outreach
2. Public Involvement and Participation
3. Illicit Discharge Detection and Elimination (IDDE) Program
4. Construction Site Stormwater Runoff Control
5. Post-Construction Stormwater Management

6. Pollution Prevention and Good Housekeeping.

Coverage under the general permit is valid during the five-year term of the permit. Permittees must pay an annual fee. In July 2021, ADEQ conducted an audit of Town of Guadalupe related to the six control measures above and found that a variety of improvements are required. The work completed by Dibble Engineering through this contract will address the audit findings, bring the Town into compliance with MS4 standards, and consequently avoid penalties or fines for non-compliance. Dibble Engineering and Town staff will work directly with ADEQ representatives to ensure that proper compliance is achieved. A PowerPoint presentation is included.

G3. NEIGHBORHOOD STREET LIGHTING IMPROVEMENT PROJECT REPORT (PAGES 23 – 37): Council will receive a report from staff and Town Engineer, Dibble Engineering regarding the recently completed street light project where 14 new streetlights. This new lighting system became operational in May 2023 and features a uniform/security focused lighting approach not previously used in Town. Neighborhood feedback and evening review of the lighting performance has been very positive.

This lighting approach will be used for future neighborhood streetlighting projects, including the upcoming Solares Neighborhood project with an estimate cost of \$807,000 funded through Maricopa County CDBG grant and SRP Neighborhood Aesthetic Fund allocation. The Solares project is scheduled for design in November 2023, and targeted for construction in mid-2024. A PowerPoint presentation is included.

G4. FISCAL YEAR 2022/2023 TOWN GENERAL FUND YEAR END REVIEW (PAGES 38 – 47): Council will receive a review of the Fiscal Year 2022/23 General Fund budget performance. The presentation will include an overview of the Town General Fund FY23 year-end fund balance of \$6.3M and the fiscal impact of two unanticipated expenditures totaling an estimated \$255,187: specifically, the Highline Recreational Path Lighting Replacement Project estimated cost increases and FY23 cost overruns of COVD/ARPA funded facility improvement projects.

The FY23 cost overruns subsequently impact the GCDC Home Renovation \$200,000 local matching amount required to receive \$1.0M in a Maricopa County ARPA grant to renovate 55 eligible Guadalupe homes. The overall fiscal impact of these two projects is an estimated \$255,187 to the FY24 General Fund. The accompanying PowerPoint provides an overview of the fiscal impact of these two projects to the General Fund. Council may provide direction to the Town Manager / Clerk.

G5. HIGHLINE RECREATIONAL PATH LIGHTING REPLACEMENT PROJECT – ARIZONA DEPARTMENT OF TRANSPORTATION PAYMENT (PAGES 48 – 76): Council will consider and may approve the payment in the amount of \$987,163 to the Arizona Department of Transportation (ADOT) for the Highline Recreational Path Lighting Replacement Project (Project), in accordance with Intergovernmental Agreement (IGA) C2022-48 between the State of Arizona through its Department of Transportation and the Town of Guadalupe, approved November 10, 2022. This payment represents the Town's Project costs. Of this \$987,163 up to \$679,500 is eligible for reimbursement from the Salt River Project (SRP) neighborhood aesthetic funds. The remaining \$501,824 Project cost is funded from a Federal Community Project grant. The total estimated cost of the project is \$1,488,987.

Project background: The purpose of this lighting project is to resolve the ongoing theft, vandalism, and maintenance problems to provide a safe, efficient, improved, and cost-effective pedestrian path lighting system. The Town of Guadalupe submitted an application seeking Federal Community Project Funding for this project in April 2021 and was awarded to the Town of Guadalupe, in February 2022, through the leadership of Congressman Gallego

On November 10, 2022, Town Council adopted Resolution No. R2022.28 authorizing the Mayor, or designee, to enter into an intergovernmental agreement (C2022-48) 22-0008725-I with the State of Arizona, acting through its Department of Transportation (ADOT) for the removal of the existing solar powered lighting system for 1.5 miles along the Highline Canal Multi-Use Pathway within the Town of Guadalupe, and replacing with an electric powered lighting system.

The accompanying PowerPoint presentation provides an overview of the current project status and will be presented at the meeting.

Minutes

Town Council Study Session Meeting Minutes

August 23, 2023



Minutes of the Guadalupe Town Council Special Meeting held on Wednesday, August 23, 2023, 1:00 p.m., at Guadalupe Town Hall, 9241 South Avenida del Yaqui, Museum Room, Guadalupe, Arizona.

A. CALL TO ORDER

Mayor Molina called the meeting to order at 1:03 p.m.

B. ROLL CALL

Councilmembers Present: Mayor Valerie Molina, Vice Mayor Ricardo Vital, Councilmember Mary Bravo, Councilmember Esteban F.V. Fuerte, Councilmember Joe Sánchez, and Councilmember Anita Cota Soto

Councilmembers Absent: Councilmember Elvira Osuna

Staff Present: Rocio Ruiz, Acting Town Manager / Clerk and David Ledyard, Town Attorney

C. CALL TO THE PUBLIC: None.

D. DISCUSSION ITEMS:

1. Maricopa County Sheriff Office Initiatives with Sheriff Paul Penzone:

a. Community Outreach

Mayor Molina opened the discussion with Sheriff Paul Penzone, Maricopa County Sheriff Office (MCSO) regarding Community Outreach. In response to a question from a Councilmember, regarding what current initiatives are in place to address the effort of changing the negative perception that portrays law enforcement officers as adversaries, particularly among younger individuals, Sheriff Penzone highlighted a historical period when there were no significant issues between young adults and law enforcement. Sheriff Penzone mentioned that the strained relationship between these groups stems from perceptions and actions of some law enforcement representatives, which have led to mistrust. The focus is on connecting with young adults, and MCSO plans to discuss specific programs designed for this purpose. Sheriff Penzone also mentioned that MCSO's community outreach division is being rebuilt, aiming to enhance relationships and reduce crime by building connections rather than solely relying on enforcement. The approach is to avoid solely using punitive measures and instead incorporate community-based initiatives to address problematic behaviors. Ron Gomez, Community Liaison for the Office of Special Programs with MCSO discussed MCSO's efforts, especially after the COVID-19 pandemic, to engage with the community, particularly young people. MCSO began with a boxing gym program two years ago, which included activities like basketball and games. However, this program was stopped due to school district preferences. This year, MCSO collaborated with the Pascua Yaqui Tribe to create a summer program, focusing on interacting with students and law enforcement. The program involved various activities such as visiting the Lakes Division, experiencing Lake Patrol activities, touring the crime lab, and exploring the sheriff's office facilities. MCSO also conducted presentations on drug awareness and psychological decision-making for young individuals. Mr. Gomez states MCSO partnered with Mayor Molina for Native American studies workshops and discussed plans to expand and continue these initiatives beyond the summer, including during fall break, to provide exposure to the broader community.

Valerie Molina
Mayor

Ricardo Vital
Vice Mayor

Mary Bravo
Councilmember

Esteban F. V. Fuerte
Councilmember

Elvira Osuna
Councilmember

Joe Sánchez
Councilmember

Anita Cota Soto
Councilmember

Agendas/Minutes:
www.guadalupeaz.org

Town Council Chambers
9241 S. Avenida del Yaqui
Guadalupe, AZ 85283
Phone: (480) 730-3080
Fax: (480)-505-5368



Valerie Molina
Mayor

Ricardo Vital
Vice Mayor

Mary Bravo
Councilmember

Esteban F. V. Fuerte
Councilmember

Elvira Osuna
Councilmember

Joe Sánchez
Councilmember

Anita Cota Soto
Councilmember

Agendas/Minutes:

www.guadalupeaz.org

Town Council Chambers
9241 S. Avenida del Yaqui
Guadalupe, AZ 85283
Phone: (480) 730-3080
Fax: (480)-505-5368

In response to a question from a Councilmember regarding if there is an age requirement to do a ride along, Sheriff Penzone stated there is an age requirement due to safety concerns. Sheriff Penzone mentioned collaborating with the autistic community and how they have brought resources like patrol deputies, investigators, horses, and helicopters to provide exposure and humanize interactions with law enforcement. This approach aims to help young adults better understand the role of law enforcement in the community. Sheriff Penzone also shared experiences of bringing the autistic community to their facilities to enhance understanding. Sheriff Penzone suggested a hybrid approach that combines elements of their previous efforts to create a law enforcement day, allowing interaction and understanding for young adults. The goal is to expand their exposure and knowledge, helping them make informed decisions about careers or navigating the justice system. Sheriff Penzone highlighted the importance of engaging those under eighteen to shape positive perceptions of law enforcement and build relationships.

Mr. Gomez discussed the Citizens Academy program. Mr. Gomez discussed their plan to hold sessions of the Citizens Academy in both English and Spanish, with the aim of expanding its reach to the Guadalupe community. Mr. Gomez mentioned that there is an upcoming English Community Academy starting on September 9th, with a high number of applicants, and a Spanish one planned for the near future. The focus is on community engagement and education, rather than just a single day event like a law enforcement day. There was discussion of what the program entails. Sheriff Penzone emphasized the importance of Citizens Academies in providing communities like Guadalupe with valuable information and transparency. MCSO's prior administration faced oversight due to issues like racial profiling and policy violations. The Citizens Academy allows community members to understand the oversight process, the agency's accountability mechanisms, and how employees are held to high standards. The program provides a sense of comfort and confidence when the community comprehends the evaluation and accountability procedures, including how variables like race are considered. The goal is to demonstrate that accountability measures are in place to prevent past issues from recurring. Sheriff Penzone acknowledged that these processes can make recruiting and retaining staff challenging, especially when it comes to uncomfortable enforcement situations.

In response to a question from a Councilmember regarding the eligibility criteria for the Academy, particularly for children who may have gotten into trouble for the first time, Sheriff Penzone clarified that the Academy primarily focuses on adults and teenagers. Sheriff Penzone mentioned that the discussion should involve juvenile probation and the courts since they manage matters related to diverting punishment for juvenile first offenses, especially non-violent ones. Sheriff Penzone emphasized that while they can facilitate the process, once a case enters the criminal justice system, it is beyond their reach to influence the outcomes. Their role is to bring relevant parties together to address these issues effectively. Mr. Gomez shared information about a program called Take Flight that replaced previous programs geared toward youth. The previous programs, Why Jail and Tough Tents were considered intimidating and confrontational. Take Flight is based on the decision points philosophy and aims to provide mentorship-like guidance to young individuals. In this program, a facilitator named Derek Jeske, from the Community Outreach Team with MCSO, offers lesson plans and mentorship scenarios to help young people make better choices and understand the consequences of their actions. The program is available in various communities and is being considered for implementation in other areas.



Valerie Molina
Mayor

Ricardo Vital
Vice Mayor

Mary Bravo
Councilmember

Esteban F. V. Fuerte
Councilmember

Elvira Osuna
Councilmember

Joe Sánchez
Councilmember

Anita Cota Soto
Councilmember

Agendas/Minutes:
www.guadalupeaz.org

Town Council Chambers
9241 S. Avenida del Yaqui
Guadalupe, AZ 85283
Phone: (480) 730-3080
Fax: (480)-505-5368

In response to a question from a Councilmember regarding a scenario involving a child with behavioral issues that may lead to law enforcement involvement, Sherrif Penzone discussed the importance of addressing adolescent behavior issues that could potentially lead to criminal behavior. They emphasized the need for a collaborative, coordinated, and consistent approach to intervention before young individuals cross a threshold from which they cannot return. The goal is to bring together various stakeholders, including law enforcement and the community, in a united effort to have a positive impact on young people's lives. Sherrif Penzone highlighted that it is crucial to avoid a confrontational or punitive approach and instead make the intervention appealing and welcoming to young individuals. The goal is to gradually involve them in programs and initiatives that they find enjoyable and beneficial. They also stressed the significance of long-term commitment, as consistent efforts over time are more likely to yield positive results in terms of behavioral change and community improvement.

In response to a question from a Councilmember regarding how Council can help addressing adolescent behavior issues, Sherrif Penzone proposed the idea of having a strategic planning meeting to discuss impactful programs, required resources, and short, mid, and long-term goals for community improvement. The plan would involve law enforcement facilitating funding for community initiatives and the community taking an active role to gain trust and respect. Sherrif Penzone suggested ideas like offering scholarships for students and creating opportunities that young adults would compete to access. Overall, the key principles emphasized were collaboration, coordination, and consistency to achieve meaningful progress.

In response to a comment from a Councilmember regarding interest in having informational resource that comprehensively outlines the services offered by MCSO, Sherrif Penzone extended an invitation for a group to visit the facility and spend a Saturday touring the Maricopa County Sheriff's Office and Justice Center. Sherrif Penzone emphasized the value of experiencing the facility firsthand as it could provide answers to questions that words alone might not address.

Sherrif Penzone expressed the intention to figure out a suitable time for a strategic planning session to address community needs effectively. Barry Roska, Executive Chief of Enforcement Operations, with MCSO suggested collaborating with other resources and organizations in the community, such as the Fire Services and Boys and Girls Club, to ensure that efforts are coordinated and not duplicated. The goal is to have a comprehensive plan that provides opportunities for the Town's youth throughout the year and involves the entire community in addressing their needs.

A Councilmember stated there has been improvement in the relationship between MCSO and the community over the past seven years. A Councilmember mentioned experiencing cultural sensitivity training and seeing a difference in how MCSO treats individuals who are known to be on the council. A Councilmember shares a personal experience involving a tragic incident with a family member and a separate incident with another family. In the latter case, a council member felt that their treatment by MCSO was different due to their council position. Sherrif Penzone acknowledge the concerns raised by the councilmember regarding the treatment of individuals based on their knowledge of their council position. Sheriff Penzone stated that in situations involving medical information, MCSO should not be involved, as medical staff has the responsibility to provide information to the next of kin. Sheriff Penzone expresses his intention to investigate why MCSO might have been involved in such a situation and highlights a potential disconnect between staff and medical personnel.

a. Neighborhood Public Safety

In response to a question from a Councilmember regarding the possibility of conducting a gun buyback program in the Town of Guadalupe, Sherrif Penzone discussed the possibility of the program in Guadalupe, with funding likely coming from the federal government. There is a focus on ensuring the program's success and determining the appropriate messaging and incentives for community members to turn in firearms. However, it is noted that in Arizona, there is legislation prohibiting the destruction of seized weapons, so alternative solutions for overseeing the firearms are being explored, such as repurposing or partnering with federal agencies like the Bureau of Alcohol, Tobacco, Firearms and Explosives (ATF) to melt down the weapons.

In response to a question from a Councilmember regarding if the gun buyback program works, Sherrif Penzone stated that getting individuals off the streets who could potentially cause harm is a productive outcome of prevention efforts. Sherrif Penzone acknowledge the challenge of quantifying prevention's impact until there is a substantial reduction in violent crime, emphasizing the importance of these efforts.

In response to a question from a Councilmember regarding a concealed carry class or an informative session about firearms and firearm safety, Sherrif Penzone stated he appreciates concealed carry classes for teaching responsibility, safety, and understanding of the consequences of firearm ownership. Sherrif Penzone suggested offering not only concealed carry classes but also responsible gun ownership and safety courses. These courses would cover topics like securing firearms at home and general gun safety. Sherrif Penzone proposes that these courses could be offered alongside a gun buyback program to promote responsible firearm ownership without infringing on Second Amendment rights. There was discussion regarding the need for educating young people about responsible gun ownership and safety. Councilmembers agree that teaching gun respect and safety is crucial, rather than advocating for a gun ban. MCSO proposed offering courses on gun safety and responsible ownership, to promote understanding and responsibility. It is noted that countries with high gun ownership, like the US, can still have low crime rates with responsible ownership.

In response to a question from a Councilmember regarding whether the use of the tip line has increased, Sherrif Penzone stated encouraging the use of the tip line is a cultural challenge that needs to be addressed. It should be fostered as a safe and praised practice within the community, even in the face of the negative stereotypes linked to reporting. The emphasis is on recognizing that providing information about individuals who have caused harm is the right thing to do and should be encouraged and celebrated.

Councilmembers and MCSO discuss community members feeling frustrated that law enforcement does not take immediate action on reported drug dealer locations. Sherrif Penzone explains the importance of having probable cause and ensuring that legal procedures are followed. The conversation highlights the need for community members to get involved and communicate their concerns, even if it feels like their efforts are not making an immediate impact. It emphasizes the importance of the community's passion and commitment to addressing issues collaboratively.



Valerie Molina
Mayor

Ricardo Vital
Vice Mayor

Mary Bravo
Councilmember

Esteban F. V. Fuerte
Councilmember

Elvira Osuna
Councilmember

Joe Sánchez
Councilmember

Anita Cota Soto
Councilmember

Agendas/Minutes:
www.guadalupeaz.org

Town Council Chambers
9241 S. Avenida del Yaqui
Guadalupe, AZ 85283
Phone: (480) 730-3080
Fax: (480)-505-5368



Valerie Molina
Mayor

Ricardo Vital
Vice Mayor

Mary Bravo
Councilmember

Esteban F. V. Fuerte
Councilmember

Elvira Osuna
Councilmember

Joe Sánchez
Councilmember

Anita Cota Soto
Councilmember

Agendas/Minutes:
www.guadalupeaz.org

Town Council Chambers
9241 S. Avenida del Yaqui
Guadalupe, AZ 85283
Phone: (480) 730-3080
Fax: (480)-505-5368

b. Communication and Coordination with Town Staff

Councilmembers discussed reviving the "Coffee with the Cop" program to facilitate better communication and coordination between the community and law enforcement. There was a lapse in this program due to a loss of communication with command staff. It was also recommended to have regular meetings between the council and law enforcement leadership, including Chief McFarland and lieutenants with MCSO, to build a relational understanding and address issues and progress collaboratively. Additionally, enhancing the visibility of such events on the Town website to keep the community informed is proposed.

Councilmembers express their appreciation for law enforcement officers who engage with the community, especially with children. Sheriff Penzone explains his approach of not wanting to be a distraction but is willing to attend community events when invited. The discussion highlights the positive relationship between the MCSO and the community, emphasizing the importance of a non-political and supportive atmosphere. Council requests real-time crime statistics, Sheriff Penzone agreed to provide such information on a quarterly basis with explanations when needed.

E. ADJOURNMENT

Motion by Councilmember Cota Soto to adjourn the Study Session Meeting; second by Vice Mayor Vital. Motion passed unanimously on a voice vote 6-0.

The meeting was adjourned at 2:12 p.m.

Valerie Molina, Mayor

ATTEST:

Jeff Kulaga, Town Manager / Town Clerk

CERTIFICATION

I hereby certify that the foregoing minutes are a true and correct copy of the minutes of the August 23, 2023, Town of Guadalupe, Town Council Study Session Meeting. I further certify the meeting was duly called and held, and that a quorum was present.

Jeff Kulaga, Town Manager / Town Clerk



DIBBLE

Small Municipal Separate Storm Sewer System (MS4)

Town of Guadalupe Small MS4 Program Management

Presented to Guadalupe Town Council

September 14, 2023

Town of Guadalupe Drainage

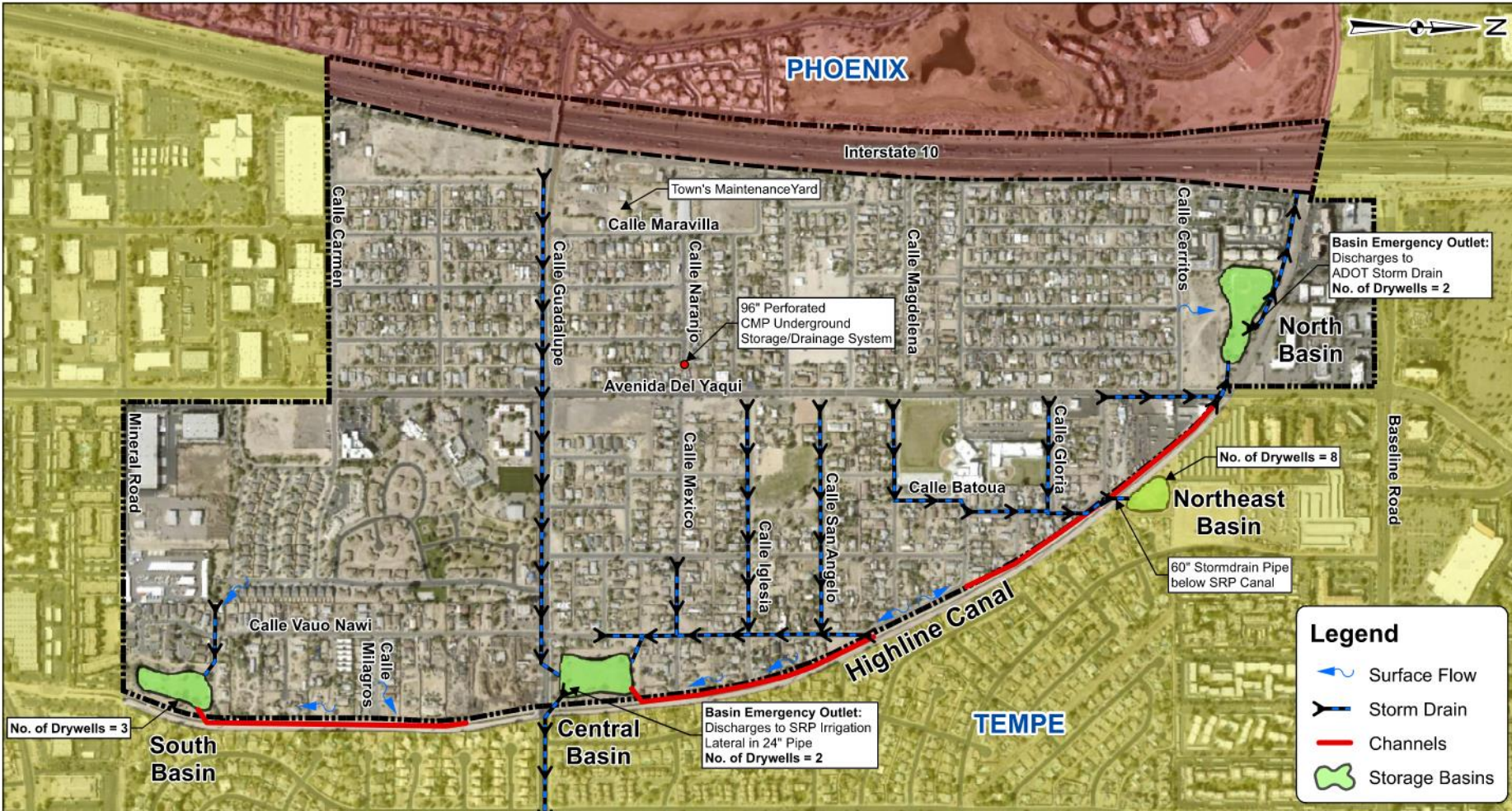

- Designed in 2001 by the Flood Control District of Maricopa County (FCDMC)
- Guadalupe watershed accumulates stormwater runoff and flows west to east
- Runoff conveyed via streets, gutter, catch basins, storm drains, and channels
- Four surface retention basins collect stormwater runoff
- Designed for 10-year storm
- Designed to discharge into state-protected waters



TOWN OF GUADALUPE
MARICOPA COUNTY
ARIZONA

STORMWATER MANAGEMENT PROGRAM (SWMP)

EXHIBIT 1

SCALE: 1"=600'

10/26/2022

- Potential Sources of Pollutants

- Residential
- Commercial
- Industrial
- Construction
- Agriculture

- Potential Pollutants

- Trash
- Toxic products
- Automobile fluids
- Pet waste
- Lawn/plant chemicals
- Pool chemicals
- Yard waste



- Arizona Department of Environmental Quality (ADEQ) regulates and enforces state-wide water quality standards
- Reissued Arizona Pollutant Discharge Elimination System (AZPDES) Small Municipal Separate Storm Sewer System (MS4) General Permit (AZG2021-002)
 - Authorizes:
 - discharge of stormwater to all protected surface waters
 - Does not authorize:
 - Illicit discharges
 - Industrial activity discharges
 - Construction activity discharges
 - Discharges to impaired or non-attaining waters

- Administers the Small MS4 program in Arizona, issuing permits and overseeing compliance for covered municipalities and urbanized areas
- Reviews and approves stormwater management plans submitted by permit holders
- Collaborates with other state and federal agencies to address water quality issues related to stormwater runoff
- Updates and revises the MS4 program to align with evolving regulations and best practices



- Improves water quality by reducing pollutants entering water bodies through stormwater runoff
- Protects ecosystems, public health, and recreational areas
- Enhances community awareness about stormwater pollution and encourages responsible practices
- Contributes to the overall mission of ADEQ in safeguarding Arizona's environment and promoting sustainability

- Five-year term
- Minimum Control Measures:
 - Public Education and Outreach
 - Public Involvement and Participation
 - Illicit Discharge Detection and Elimination (IDDE) Program
 - Construction Site Stormwater Runoff Control
 - Post-Construction Stormwater Management
 - Pollution Prevention and Good Housekeeping
 - Compliance and Enforcement

Household Stormwater Pollution Prevention

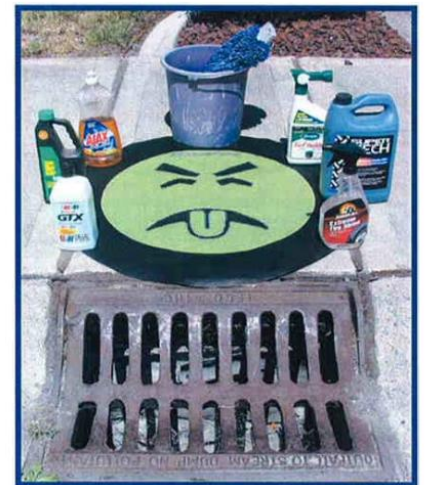

Kids Working Together With Guadalupe = Cleaner Schools,
Cleaner Roads, Cleaner Parks

Town Office 480-730-3080
Report spills, Trash to Marc Stern,
Building Inspector 480-505-5380

Permit Non-Compliance

- Minor Violations: Minor Paperwork Errors, missed deadlines, or administrative oversights
- Moderate Violations: Inadequate stormwater management practices or minor pollution incidents
- Significant Violations: Measurable harm to water quality, ecosystems, or public health
- Repeat or Severe Violations: Significant environmental impact



- Notice of Violation
- Consent Order
- Injunctive Relief
- Penalties under state and federal laws
 - Civil actions
 - Criminal penalties
 - Administrative penalties

- ADEQ conducts 8 random Small MS4 audits per fiscal year
- Town was audited in June 2021
- ADEQ Water Surface Protection Inspections & Compliance Enforcement Unit Recommendations:
 - Update Storm Water Management Plan (SWMP)
 - Develop Enforcement Response Plan (ERP)
 - Conduct Public Education and Outreach
 - Develop Illicit Discharge Detection and Elimination Program (IDDE)
 - Conduct Annual Employee Training
 - Track/Record Construction Activity Stormwater Runoff Control
 - Develop Inspection Schedule for Municipal Facilities (Good Housekeeping)

Small MS4 Program Progress

Permit Compliance Requirement	Complete	In Progress	Notes
Storm Water Management Plan (SWMP)	X		Revised SWMP to comply with Small MS4 General Permit
Enforcement Response Plan (ERP)	X		Developed ERP guidelines and procedures
Public Education and Outreach		X	Currently developing and implementing public education and outreach program, materials, and schedule
Annual Employee Training		X	Currently developing employee training program and schedule.
Illicit Discharge Detection & Elimination Program (IDDE)	X		Developed the IDDE program and procedures
Construction Activity Stormwater Runoff Control	X		Developed documents outlining proper construction stormwater runoff control
Good Housekeeping	X		Developed management and inspection procedures for municipal facilities

- Update online portal of new Storm Water Management Plan (SWMP) and current ADEQ report
- Facilitate continual learning of staff and all parties involved with the Town SWMP
- Develop a virtual message board that keeps up-to-date information **about the Town's SWMP available to the public (social media)**
- Support continual annual inspections of basins, municipal facilities, construction sites, public spaces, and businesses
- **Annually update SWMP to fit the Town's needs in accordance with the General Permit**
- Complete and submit AZPDES Small MS4 Annual Report to ADEQ documenting program compliance



Questions? & Thank you

Town of Guadalupe Small MS4 Program Management

Presented to Guadalupe Town Council
September 14, 2023



East Guadalupe - Neighborhood 14

Subdivision Block 14 TR A-G

Update on Streetlighting Improvement Project

Calle Batoua, Calle Biehn, Calle Carlos, Calle Tomi & Calle Guadalupe

September 14, 2023

By Seth Chalmers, PE



**East Guadalupe
Neighborhood 14**
35 ft Mounting
Height, 6.5 ft set back

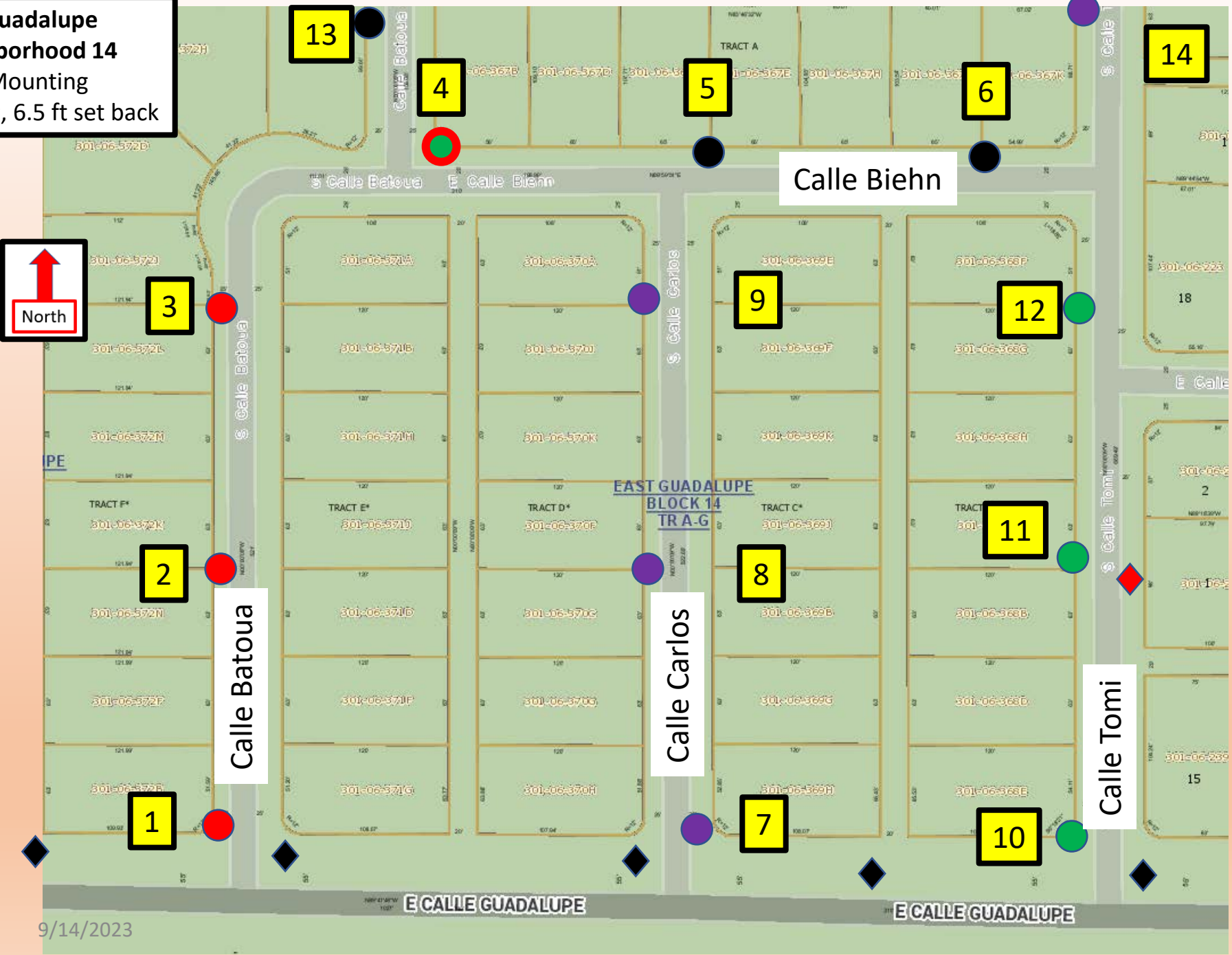

24

Legend

- Cooper
- GE Current
- New Acuity – AEL
- Old Acuity – AEL
- Signify
- ◆ Existing Roadway Light To remain
- ◆ Mailbox Light on wood pole
- # Pole Number

All lights have been installed and became operational in
Mid-May 2021
Lot widths are 63 feet.
Typical pole spacing is 189 feet

**Town of Guadalupe:²⁵
New Residential
Or Neighborhood
Streetlighting Standard**

**35-foot
Mounting Height**

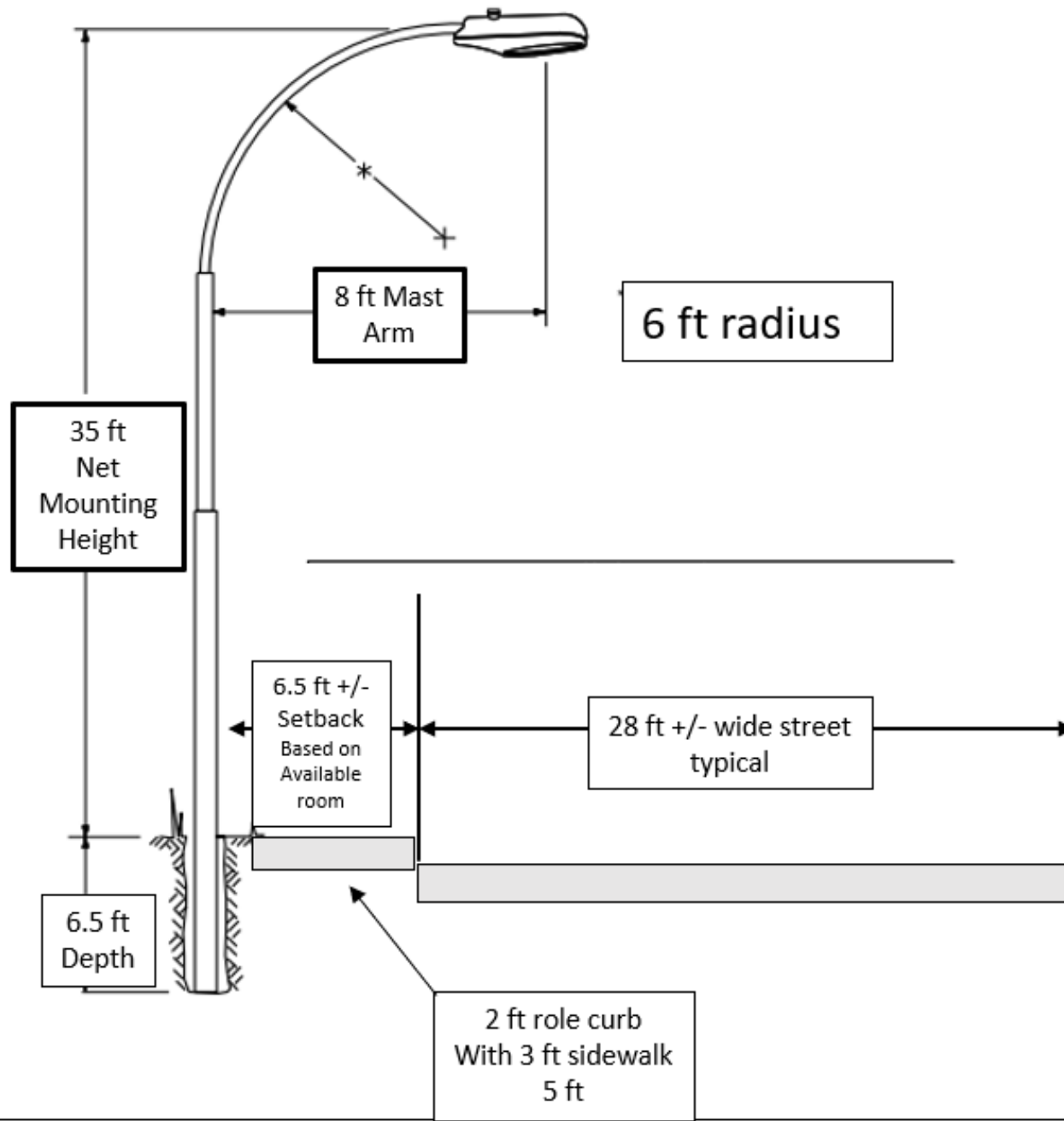

Based on SRP "Lighting Compatible Units LED Streamline Page 7-2-1

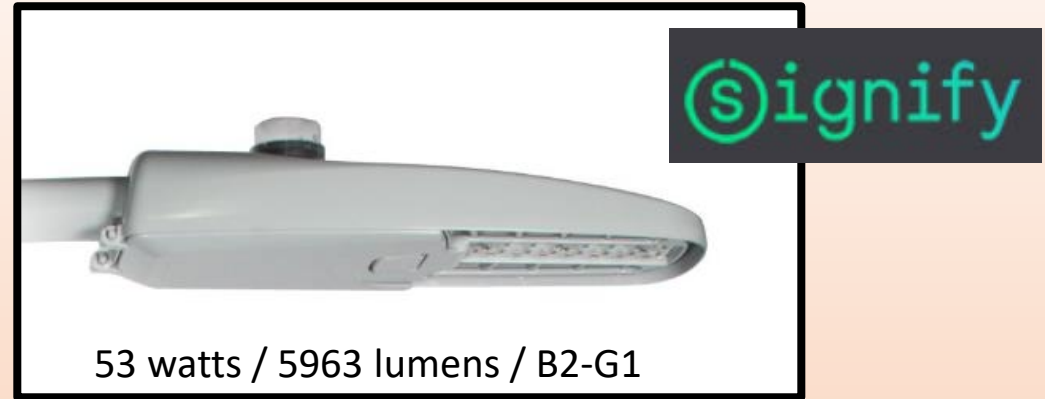

Light Make and Models Installed (4 makes and 5 models) – All are zero uplight
 Target Illuminance Performance: . 6 footcandle average with below 7 to

54 watts / 6744 lumens / B2-G2



51 watts / 6392 lumens / B2-G2





9/14/2023



5

Typical Neighbor Streetlighting



Typical Mathematical Uniformity Ratio For Residential Roadway Lighting is **6 to 1**

The lower the ratio the Less light to dark is Noticeable between lights

Uniformity Ratio Defines this Light To Dark to Light

The higher the ratio The more pronounced The light to dark is



VS



Uniform – New System for East Guadalupe 14 Neighborhood 14

Not Uniform – Typical of our Existing Systems

Uniformity – How Evenly is the Light Distributed Over the Area Being Lit.
It is the main metric to assess how good a lighting system is in improving visibility potential.
Lots of light without a good uniformity can be very ineffective. In fact, it can reduce visibility potential significantly.

COMMUNITY FEEDBACK

Facebook post – May 18, 2023

- Reach: 2,161
- Reactions: 64
- Shares: 3
- Comments: 33

Many positive comments

- *Keep up the good work*
- *Awesome job*
- *Thank you*

Other light improvement location suggestions

- Biehn Park
- Highline Canal (Underway to be bid shortly)
- Calle Carmen

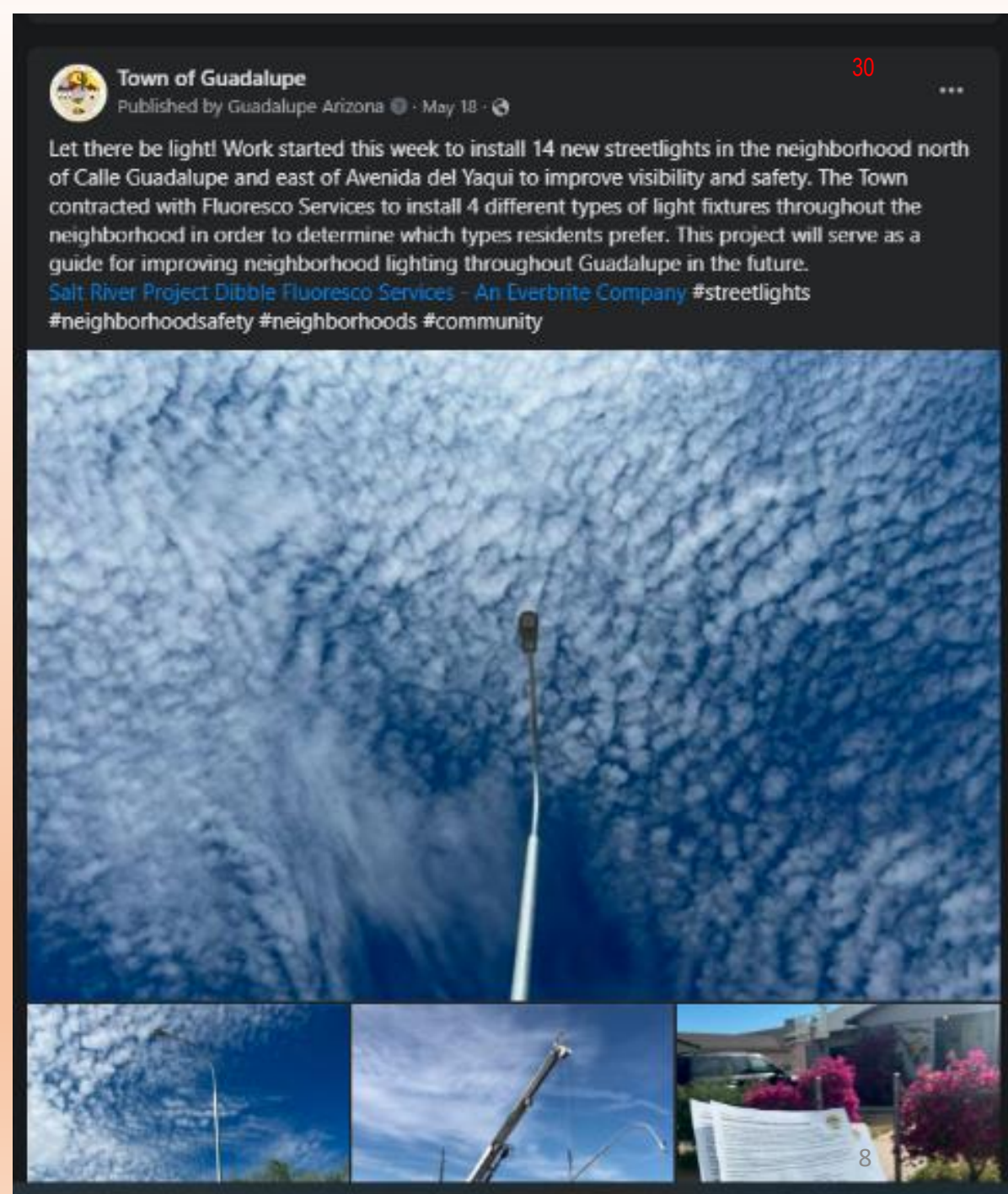

Calle Tomi



Calle Batoua



Calle Carlos



B

Next Up the Solares Addition Full Replacement Concept Using Neighborhood 14 Approach
 Typical lot width is 50 feet

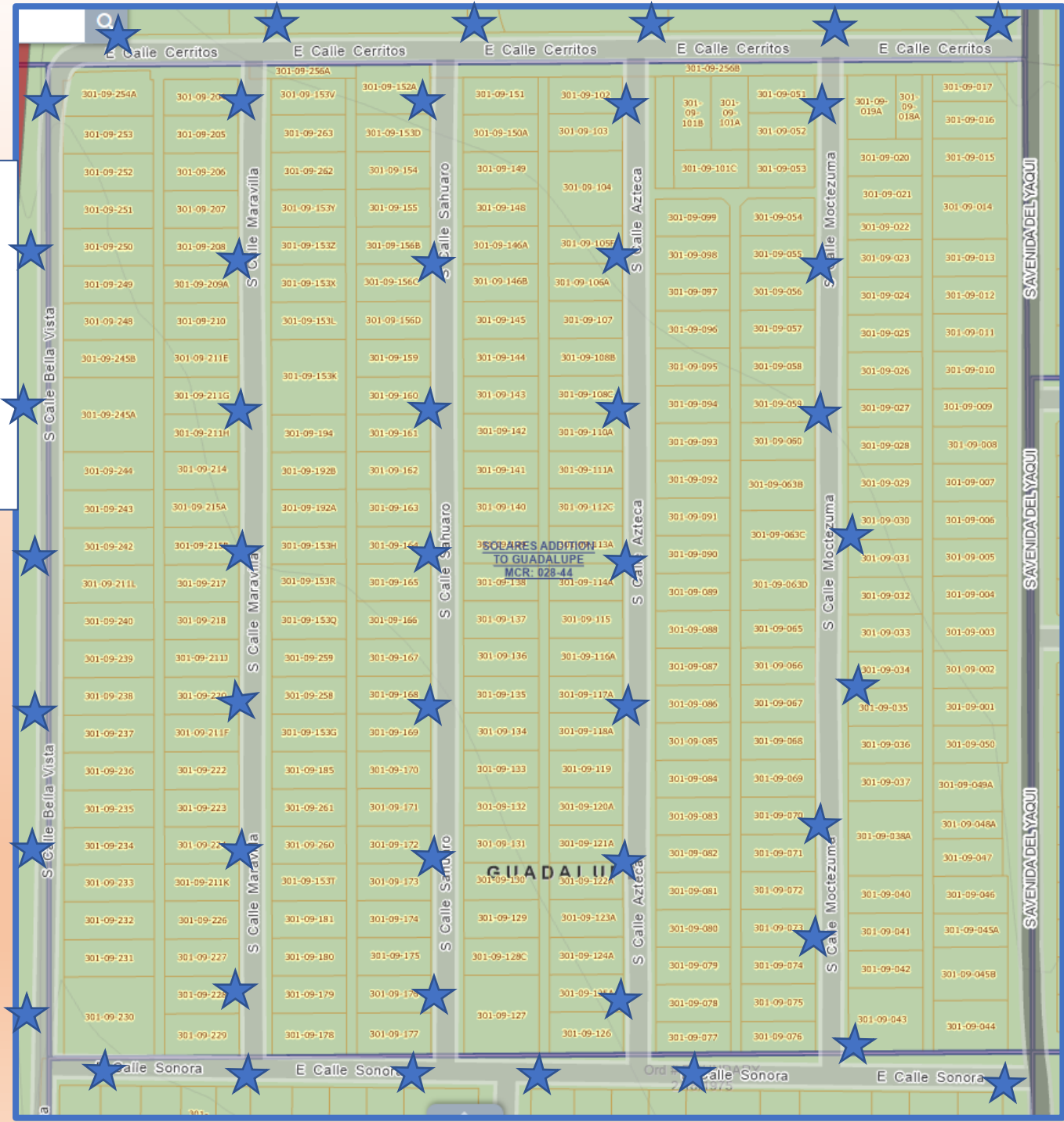

Currently 41 Existing Lights
 Not Shown
 Lights electrical service is provided via overhead secondary direct from SRP.

★ - 48 New Lights Anticipated – Net Gain 7
 Design to start November 2023
 Construction in Mid 2024

C

Guadalupe Replatted Full Replacement



34 New Lights Design November 2023 Construction 2025

Orange star: Duplicate lights from Solares neighborhood conceptual layout

Currently 16 Existing Lights Not Shown

35

D

Gastello – Sonorita
Full Replacement

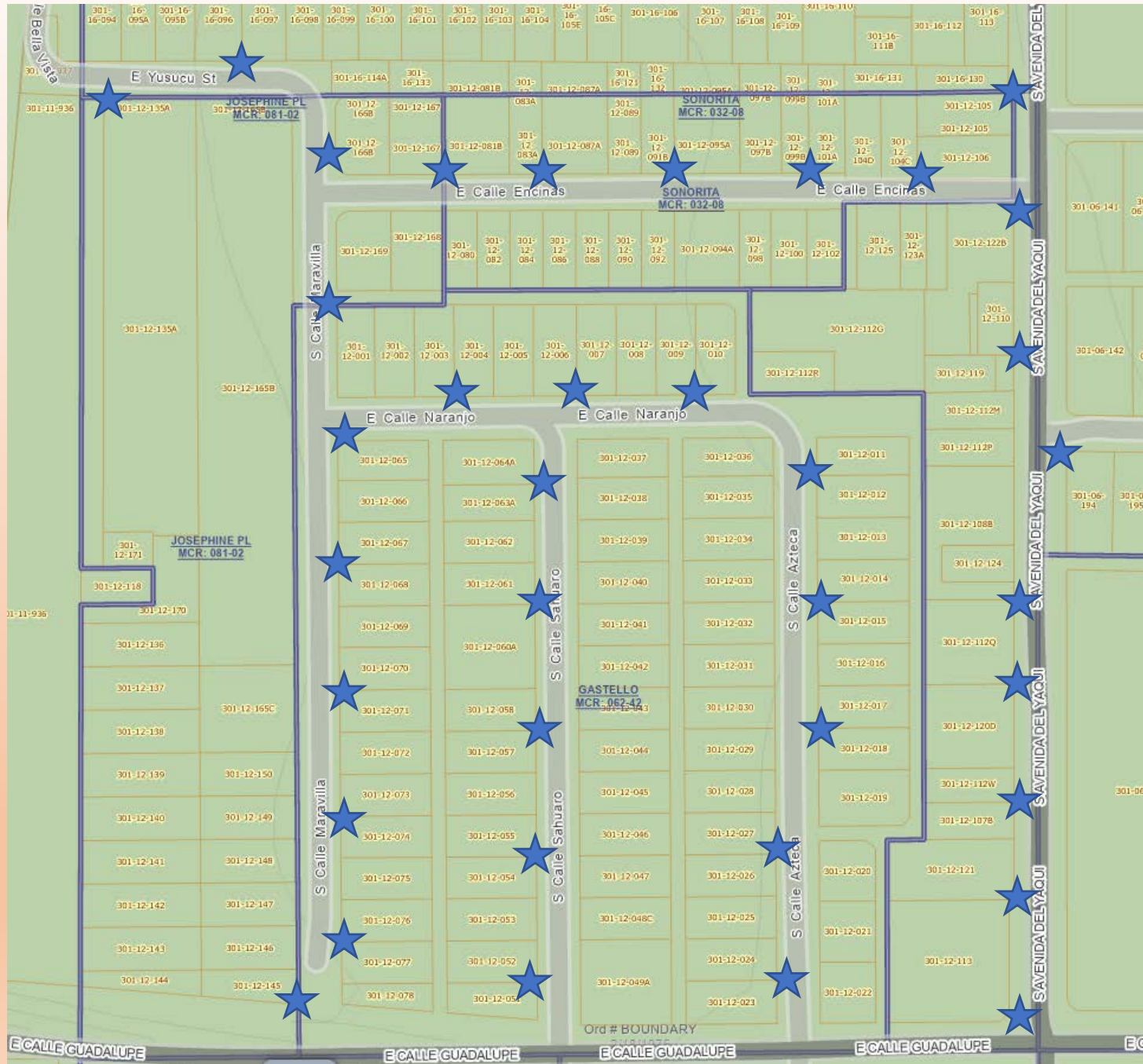

★ 36

37 New Lights
Design
November
2023
Construction
2025

Currently 20
Existing Lights
Not Shown



East Guadalupe - Neighborhood 14

Subdivision Block 14 TR A-G

Update on Streetlighting Improvement Project

Calle Batoua, Calle Biehn, Calle Carlos, Calle Tomi & Calle Guadalupe

September 14, 2023

By Seth Chalmers, PE





**Fiscal Year 2022-2023
General Fund Year End
Budget Summary
&
Unanticipated General Fund Impacts**

September 14, 2023



**Fiscal Year 2022-2023
General Fund Year End Budget Summary**

FY22-23 General Fund Year End Summary	
Revenues	\$6,777,143
Expenditures	\$5,639,091
Annual Balance	\$1,138,052

- Revenues exceeded expenditures
- Remaining American Rescue Plan Act (ARPA) funds offset certain General Fund recurring operating costs and capital costs
- ARPA funds exhausted and no longer available
- Improved fiscal position
- Continue to remain cautious

General Fund Performance FY17 - FY23

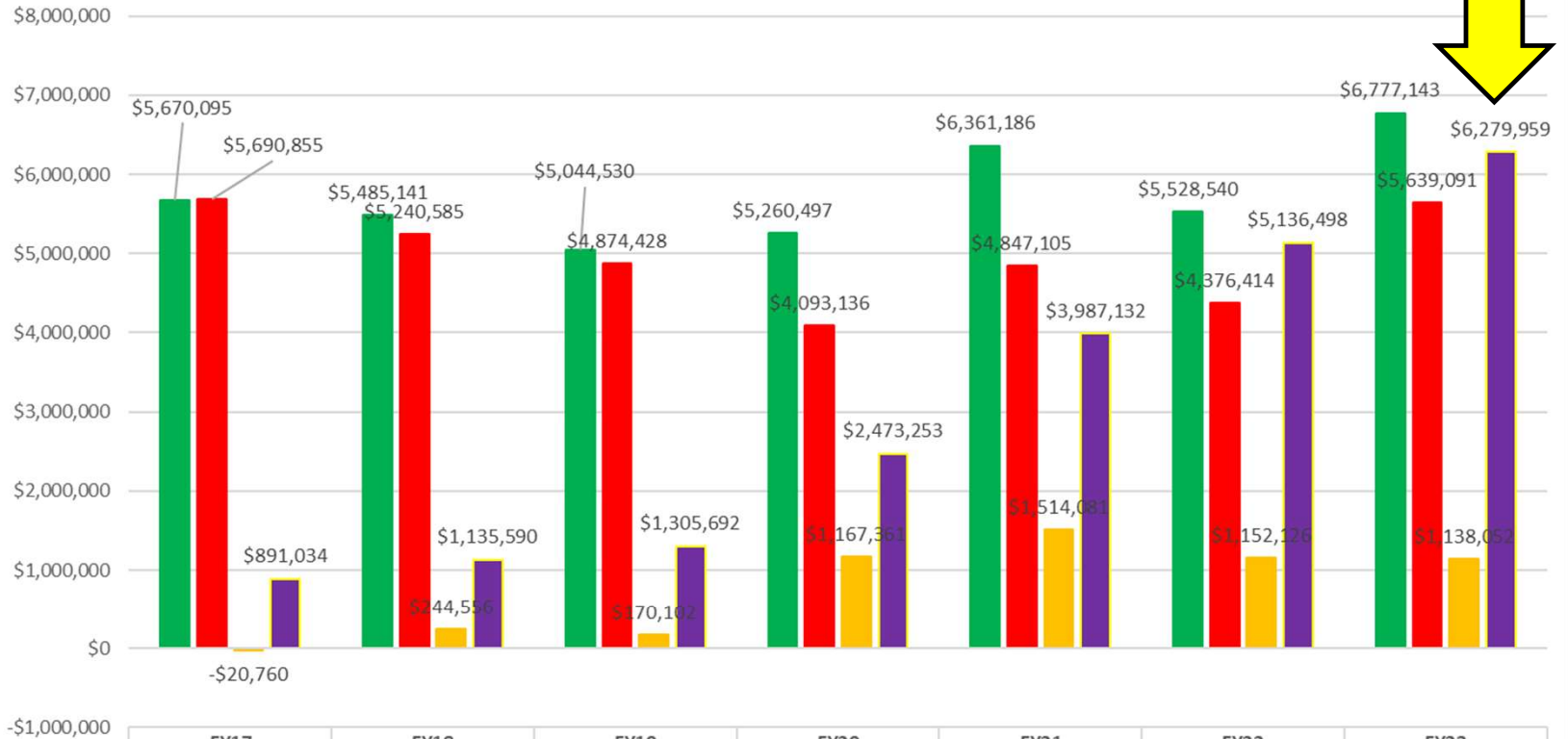

	FY17	FY18	FY19	FY20	FY21	FY22	FY23
General Fund Revenues	\$5,670,095	\$5,485,141	\$5,044,530	\$5,260,497	\$6,361,186	\$5,528,540	\$6,777,143
General Fund Expenditures	\$5,690,855	\$5,240,585	\$4,874,428	\$4,093,136	\$4,847,105	\$4,376,414	\$5,639,091
Revenues (over/under) expenditures	-\$20,760	\$244,556	\$170,102	\$1,167,361	\$1,514,081	\$1,152,126	\$1,138,052
Year End Fund Balance	\$891,034	\$1,135,590	\$1,305,692	\$2,473,253	\$3,987,132	\$5,136,498	\$6,279,959

■ General Fund Revenues
 ■ General Fund Expenditures
 ■ Revenues (over/under) expenditures
 ■ Year End Fund Balance

Fiscal Year 2022-2023 General Fund Year End Budget Summary



	Audited	Audited	Audited	Audited	Audited	Audited	Unaudited
	FY17	FY18	FY19	FY20	FY21	FY22	FY23
General Fund Revenues	\$5,670,095	\$5,485,141	\$5,044,530	\$5,260,497	\$6,361,186	\$5,528,540	\$6,777,143
General Fund Expenditures	\$5,690,855	\$5,240,585	\$4,874,428	\$4,093,136	\$4,847,105	\$4,376,414	\$5,639,091
Revenues (over/under) expenditures	-\$20,760	\$244,556	\$170,102	\$1,167,361	\$1,514,081	\$1,152,126	\$1,138,052
Year End Fund Balance	\$891,034	\$1,135,590	\$1,305,692	\$2,473,253	\$3,987,132	\$5,136,498	\$6,279,959

Key General Fund Findings:

- ✓ Six consecutive years of revenues exceeding expenditures.
- ✓ COVID / ARPA funds offset eligible operational costs and funded capital projects.
- ✓ \$6.3M General Fund balance.
- ✓ FY24 General Fund adopted budget = \$7.4M
- ✓ 25% of \$7.4M = \$1.85M

Cautions:

- ✓ Reliable stable recurring local sales tax base remains a challenge.
- ✓ Town buildings, parks, cemetery, streets, signs, alley in need of repair/replacement.
- ✓ Town wages remain comparatively low.



Fiscal Year 2022-2023 General Fund Year End Budget Impacts

FY2022-2023 General Fund	Unaudited
	FY23
General Fund Revenues	\$6,777,143
General Fund Expenditures	\$5,639,091
Revenues (over/under) expenditures	\$1,138,052
Year End Fund Balance	\$6,279,959

Policy Decisions: Unanticipated cost to General Fund

#1: Highline Canal Lighting Project

- ✓ Path Lighting Payment to ADOT = \$987,163.00
- ✓ Due September 15, 2023.
- ✓ With eligible \$679,300 reimbursements from SRP, estimated additional General Fund expenditure / impact = \$55,187

#2: Local Match for GCDC Home Renovation

- ✓ \$200,000 Local Match to receive \$1.0M in Maricopa County ARPA funds for GCDC to renovate 55 eligible Guadalupe homes.
- ✓ FY2022-203 Town COVID / ARPA exhausted. \$200,000 forecasted as a carry forward to FY24 expended.
- ✓ Consideration to approve IGA with County scheduled for September 28 Town Council meeting.



**Fiscal Year 2022-2023
General Fund Year End Budget Impacts**

General Fund Impact = \$255,187 *

FY2022-2023 General Fund	Unaudited
	FY23
General Fund Revenues	\$6,777,143
General Fund Expenditures	\$5,639,091
Revenues (over/under) expenditures	\$1,138,052
Year End Fund Balance	\$6,279,959
FY2022-2023 General Fund	Impact
Year End Fund Balance	\$6,279,959
Highline Canal Lighting	-\$987,163
Home Revocation Local Match	-\$200,000
Immediate Balance	\$5,092,796

Eligible SRP Aesthetic Funds Reimbursement	\$679,500
Approved FY24 Capital Project Fund	\$252,476
Estimated Long Term Balance	\$6,024,772
Year End Balance	\$6,279,959
Estimated Cost w/SRP Reimbursment	\$5,872,296
Estimated Total Fiscal Impact	\$255,187
#1 Highline Canal Lighting	\$55,187
#2 Home Renovation Local Match	\$200,000
Unanticiapated General Fund Impact	\$255,187

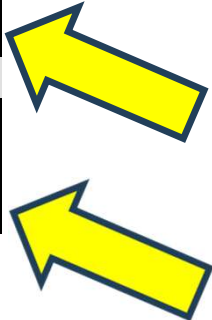

*** eligible SRP reimbursement & construction costs**



Fiscal Year 2022-2023 General Fund Year End Budget Impacts

\$255,187 Expenditure Value ?

#1: Highline Canal Lighting Project

- ✓ 21% Town’s Responsibility
- ✓ 79% SRP Funds and Federal Grant

Project Revenues	REVISED	
Federal Communtiy Project	\$501,824	34%
SRP Aesthetic	\$679,500	46%
Guadalupe FY24 Capital Budget	\$252,476	17%
Guadalupe Additional Costs	\$55,187	4%
revenue total	\$1,488,987	100%

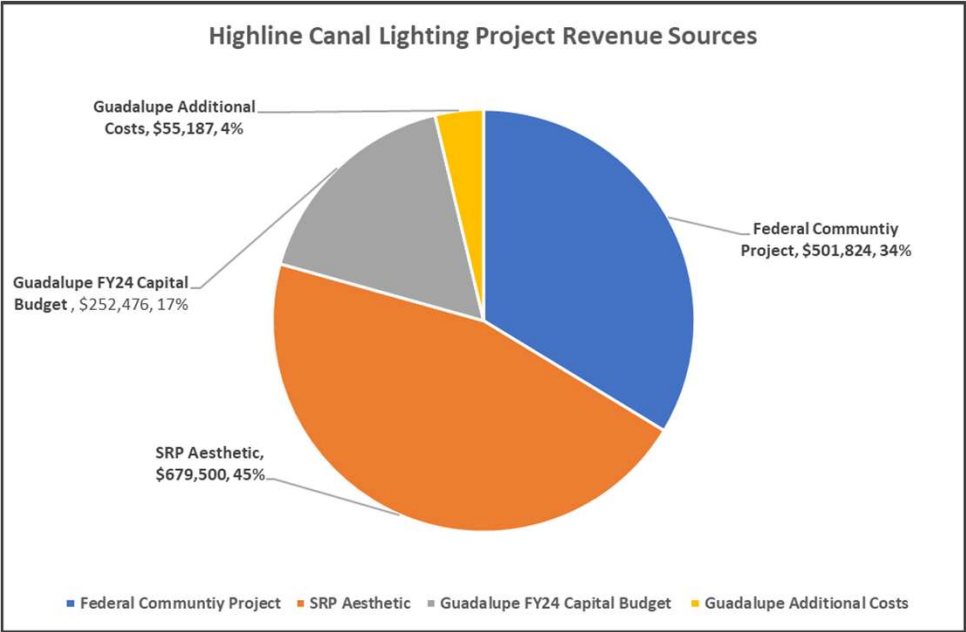



**Fiscal Year 2022-2023
General Fund Year End Budget Impacts**

\$255,187 Expenditure Value ?

Project Revenues	REVISED	
Maricopa County ARPA	\$1,000,000	83%
Guadalupe Match	\$200,000	17%
revenue total	\$1,200,000	100%

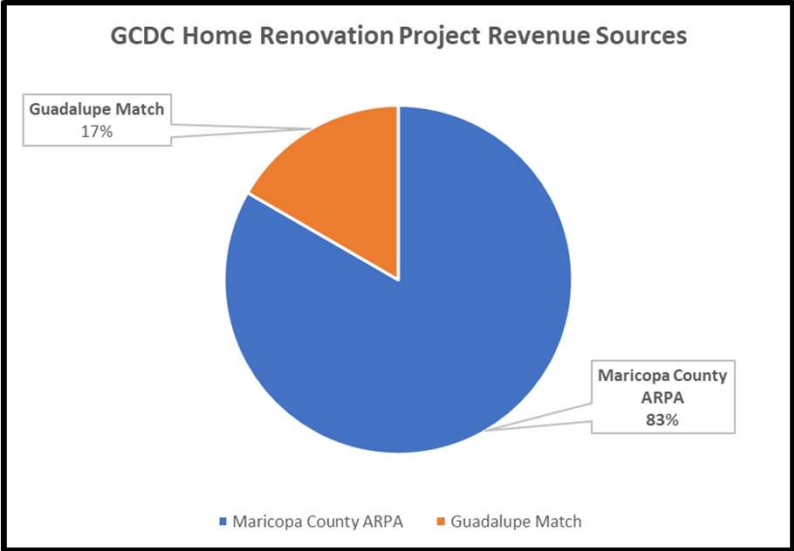

#2: Local Match for GCDC Home Renovation

Causes of Town \$200,000 COVID/ARPA cost overruns:

- ✓ **General increase in construction and material costs**
- ✓ **Unexpected projects repairs:**
 - ✓ Senior Center floor, patio drainage, lighting & electrical
 - ✓ Senior Center kitchen floor, drain, tile, restrooms
 - ✓ Library restroom, electrical, paint.
 - ✓ Council Chamber audio/visual
 - ✓ Mercado restroom, suites.



**Fiscal Year 2022-2023
General Fund Year End Budget Impacts**

General Fund Impact = \$255,187*

Recommend approval of both expenditures:

#1: Highline Canal Lighting Project

#2: Local Match for GCDC Home Renovation

The General Fund balance has the capacity to absorb an estimated \$255,187.

The 20% of Town funds for both projects is a wise investment.

The \$200,000 of ARPA funded projects repaired and renovated Town facilities.

*** eligible SRP reimbursement & construction costs**



Thank you.

**Fiscal Year 2022-2023
General Fund Year End
Budget Summary
&
Unanticipated General Fund Impacts**

September 14, 2023



Highline Canal Recreational Path Lighting Replacement Project

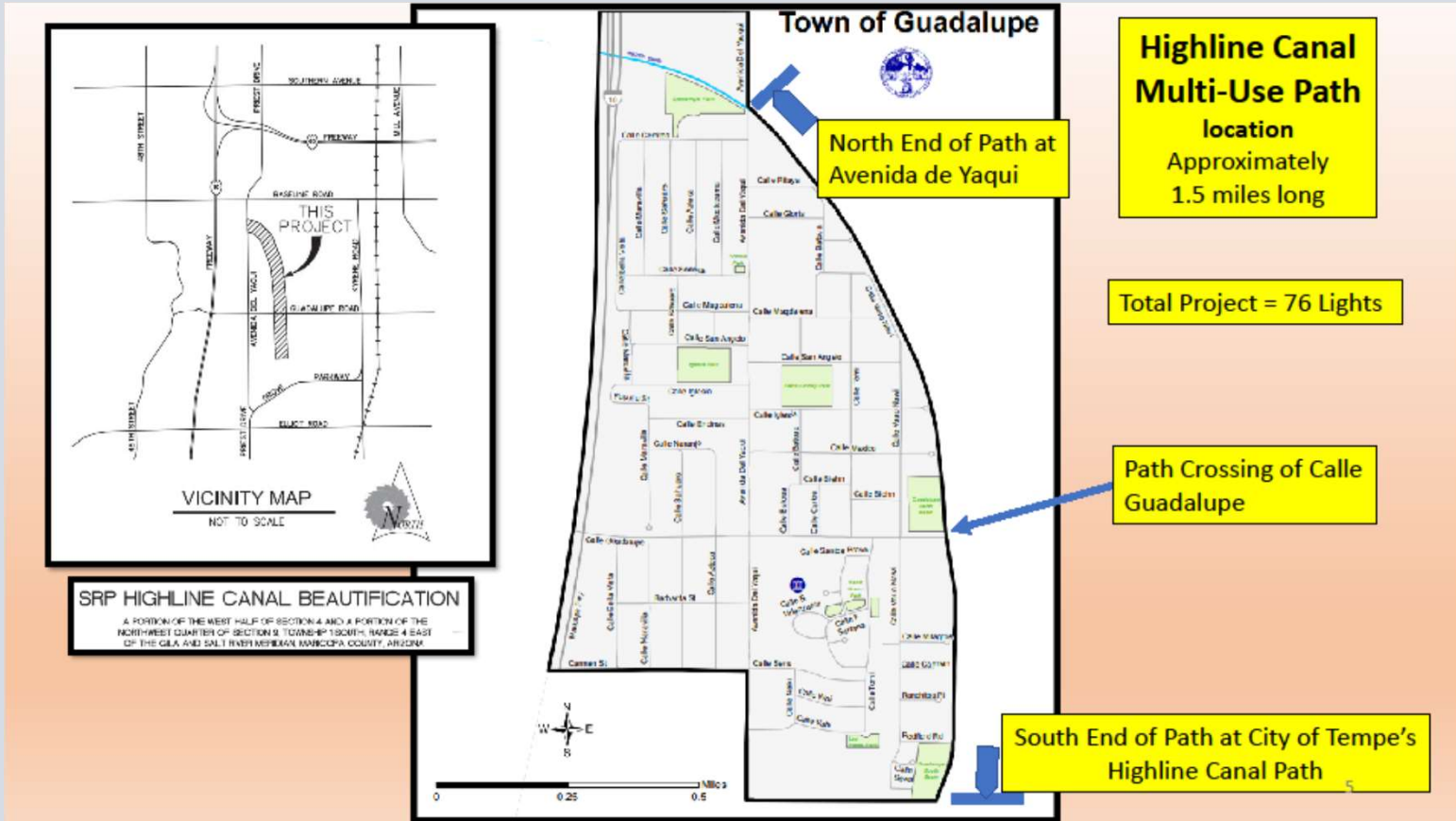



Highline Canal Recreational Path Lighting Replacement Project

Project Scope

Replace 76 inoperable solar powered path lighting fixtures and poles to improve path safety along the 1.5-mile path.

Replace solar lights with conventional hard-wired lights involving:

- Remove existing pedestrian lighting poles, battery boxes, fixtures, solar panels.
- Install new pedestrian lighting poles, fixtures, new power conduit, pull boxes, trenches and electrical cabinets.

REVISED Estimated Project Cost: \$1,488,987





Highline Canal Recreational Path Lighting Replacement Project

	Sept. 14		Sept. 14		Sept. 28	
Project Revenues	Presented		Corrected		REVISED	
Federal Communtiy Project	\$501,824	55.3%	\$501,824	47.4%	\$501,824	35.0%
SRP Aesthetic	\$305,300	33.7%	\$305,300	28.8%	\$679,500	47.4%
Guadalupe FY24 Capital Budget	\$100,000	11.0%	\$252,476	23.8%	\$252,476	17.6%
revenue total	\$907,124	100.0%	\$1,059,600	100.0%	\$1,433,800	100.0%



REVISED Project Funding Sources:

- Federal: Congressman Gallego - April 2021.
- SRP Aesthetic Fund - FY22, FY 23, FY24 allocations \$374,200 additional
- Town General Fund – FY24 adopted budget \$252,476
- **Total increase = \$526,676**

Highline Canal Lighting Project:

Revised Revenues & Expenditures:

Increased Revenues:

\$374,200	SRP reimbursement
\$152,476	Town FY24 Budget
\$526,766	Total

Cost Reductions:

\$168,743 ADOT

Savings: \$695,419

Remaining: \$55,187*

*estimated SRP funds & construction costs

	Sept. 14		Sept. 28	
Project Revenues	Corrected		REVISED	
Federal Communtiy Project	\$501,824	47.4%	\$501,824	35.0%
SRP Aesthetic	\$305,300	28.8%	\$679,500	47.4%
Guadalupe FY24 Capital Budget	\$252,476	23.8%	\$252,476	17.6%
revenue total	\$1,059,600	100.0%	\$1,433,800	100.0%

	Sept. 14		Sept. 28	
ADOT Estimated Costs:				
Project Materials, Construction	\$1,331,620	80.3%	\$1,217,800	81.8%
Construction Engineering	\$287,410	17.3%	\$210,297	14.1%
Post Design Services	\$11,500	0.7%	\$0	0.0%
Construction Contingency	\$22,200	1.3%	\$60,890	4.1%
Public Relations	\$5,000	0.3%	\$0	0.0%
total cost	\$1,657,730	100.0%	\$1,488,987	100.0%

Shortfall: expenditures exceed revenues	\$598,130		\$55,187	
--	------------------	--	-----------------	--

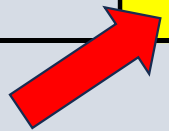
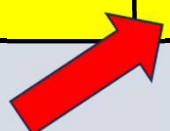
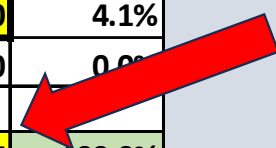



Highline Canal Lighting Replacement Project

Project Revenues	REVISED	
Federal Communtiy Project	\$501,824	34%
SRP Aesthetic	\$679,500	46%
Guadalupe FY24 Capital Budget	\$252,476	17%
Guadalupe Additional Costs	\$55,187	4%
revenue total	\$1,488,987	100%

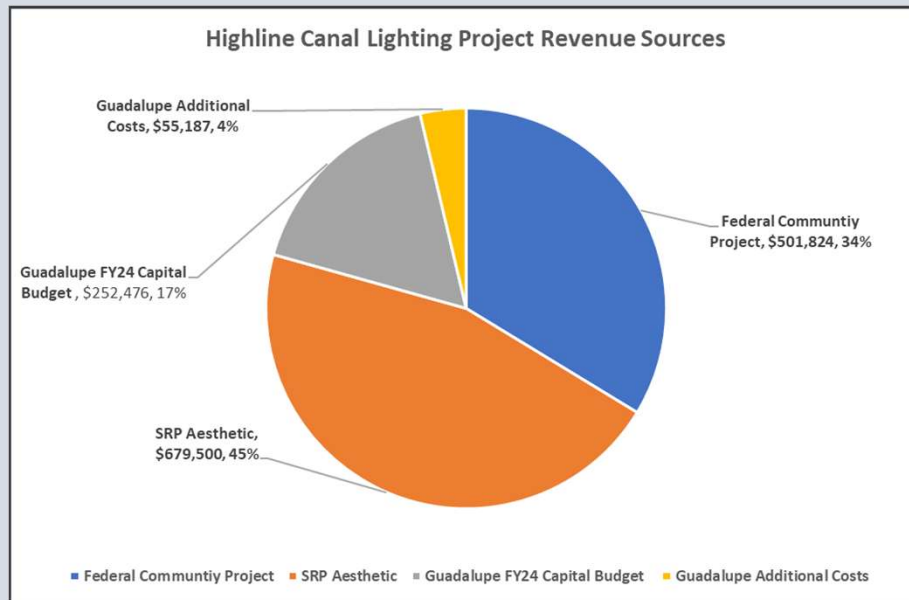

**Revised Total
Estimated Town
Costs:**

\$307,663

21% of total



Highline Canal Lighting Replacement Project Checklist

Project Next Steps, prior to September 14th:

- ✓ Consider community input. **Completed**
- ✓ Seek additional financial resources. **SRP Aesthetic Funds**
- ✓ Seek alternative designated project agent to ADOT. **Poor timing**
- ✓ Determine project budget shortfall. **Refined cost estimate**
- ✓ Determine impact to Town General Fund \$6.3M balance. **\$55,187**
- ✓ Present recommendations at September 14 Town Council Meeting. **Recommend approval of \$987,163 to ADOT**

Original Plan Detail

Specifications called for: 24 Volt DC Battery pack with 10-year warranty that is charged by 240 watt solar panel. Aluminum poles of 9', 15', 25' & 30' were also called for?

These low mounting heights Are not very effective or efficient For light delivery

12 ft +/- ?

20 ft +/- ?

Typical Installation "Solar Light" installation on the North Segment (North of Calle Guadalupe Rd.) – 48 such installations, only 4 of the installations are the taller poles.

1. Policy decision: Approve ~~\$1.15M~~ \$987,163 payment to ADOT



Highline Canal Recreational Path Lighting Replacement Project

DETAILED ESTIMATE RECAPITULATION

0000 MA GUA T039201C
GUA-0(206)T
Highline Canal; Mineral Rd to Avenida Del Yaqui

CREATED: 8/21/2023
REVISED: 8/28/2023
ENGINEER: TMR

DESCRIPTION	FHWA CODE	ESTIMATED COST	FEDERAL PARTICIPATION	FEDERAL FUNDS 100.00%	LOCAL FUNDS 100.00%	LENGTH IN MI
Highline Canal Lighting	28	1,217,800	1,217,800	230,637	987,163	1.500
SUBTOTAL		1,217,800	1,217,800	230,637	987,163	
CONSTRUCTION ENGINEERING	Fixed 17	210,297	210,297	210,297		
CONSTRUCTION CONTINGENCY	5% 28	60,890	60,890	60,890		
PROJECT TOTAL:		1,488,987	1,488,987	501,824	987,163	1.500

NOTE:

**REVISED ADOT IGA Invoice
from \$1.15 M to \$987,163
Due September 15, 2023**



Highline Canal Recreational Path Lighting Replacement Project

Construction Schedule:

1. October 1: Final Plans, Design, Engineering.
2. Mid October: Solicit / advertise for Bids.
3. January 2024: Award bid / contract.
4. February 2024: Begin construction.
5. February – July 2024: Construction / Canal Path Closed / **SRP Reimbursement.**
6. July 2024: Estimated Project Completion.



Highline Canal Recreational Path Lighting Replacement Project

Thank you



Town Council Meeting
September 14, 2023



Highline Canal Recreational Path Lighting Replacement Project

Thank you



Town Council Meeting
September 14, 2023





Highline Canal Recreational Path Lighting Replacement Project

Project Background

In 2013, the Town of Guadalupe established the recreational path and beautified the Highline Canal by installing a concrete path, landscaping, security fence, benches, artwork, and installing solar lighting.

2013-2014: Design, Engineering, Planning

2014-2015: Construction, Completion

Total Cost: \$1,035,720





Highline Canal Recreational Path Lighting Replacement Project

76 path lights in disrepair

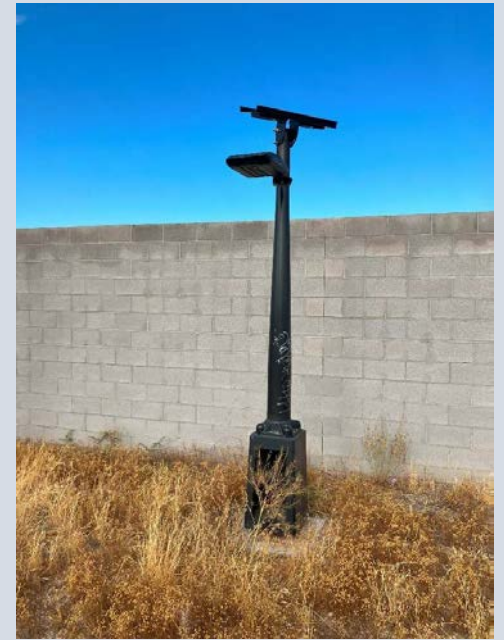



Highline Canal Recreational Path Lighting Replacement Project

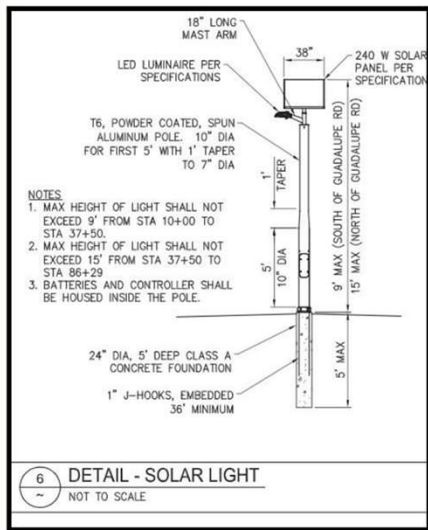

Original Plan Detail

Specifications called for: 24 Volt DC Battery pack with 10-year warranty that is charged by 240 watt solar panel. Aluminum poles of 9', 15', 25' & 30' were also called for?



Typical Installation "Solar Light" installation on the North Segment (North of Calle Guadalupe Rd.) – 48 such installations, only 4 of the installations are the taller poles.

Highline Canal Recreational Path Lighting Replacement Project

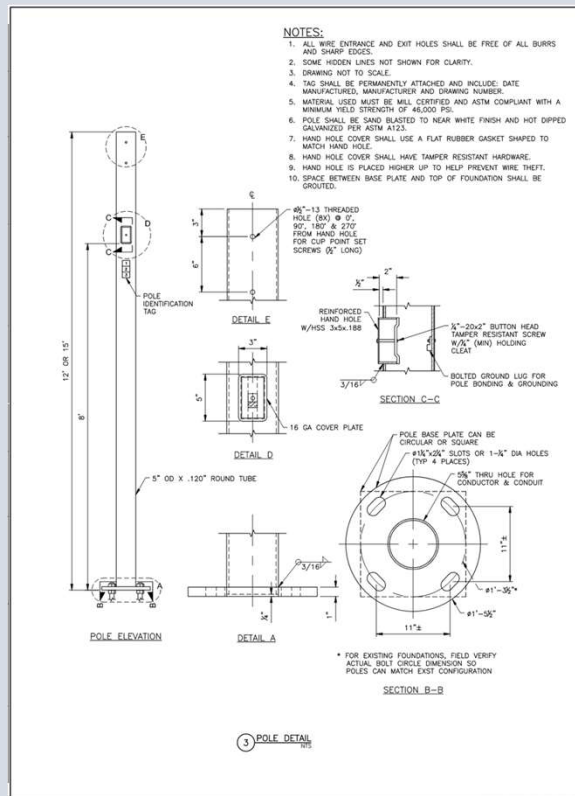

Example of new light, fixture and pole

12' to 15' in height



Highline Canal Recreational Path Lighting Replacement Project

Project Purpose

The purpose of the project is to improve pedestrian and bicyclist safety.

- Since the 2015 completion, the solar lighting system has been subjected to repeated vandalism and theft.
- Replacement solar battery pack cost over \$500 each.
- These packs were continuously stolen, no longer affordable to replace.
- Path lighting has been abandoned, while funding sources were sought.





Highline Canal Recreational Path Lighting Replacement Project

Project Outreach

Community Outreach letters sent 44 adjacent property owners and 12 neighboring agencies.

Three responses:

- City of Tempe – proposed lighting
- Maricopa County Parks & Recreation – Maricopa Trail
- Adjacent property owner and neighbor – several questions.





DTALA2024000005DT0038

Remit to: ARIZONA DEPARTMENT OF TRANSPORTATION
Local Agency
206 S 17TH AVE
MAILDROP 203B
PHOENIX AZ 85007

Bill to: Guadalupe, Town Of
9241 S Avenida Del Yaqui
Guadalupe AZ 85283

Customer Name		INVOICE
Guadalupe, Town Of		
Customer Number	Invoice Number	Invoice Date
DT0038	LA2024000005	08-28-23
	ARDept/BPRO	Due Date
	DTA:LA010	08-20-23
	Amount Due	Amount Enclosed
	\$987,163.00	

Payment Method: Check Money Order

Please check if address has changed. Write correct address on back of stub and attach with payment

Please write Invoice No on front of check or Money Order. DO NOT MAIL CASH

----- Please detach the above stub and return with your remittance. -----

ADOT
ORIGINAL

Customer Number	Original Invoice Date	Original Due Date
DT0038	08-28-23	08-20-23

Customer Name	Invoice Number	Invoice Date
Guadalupe, Town Of	LA2024000005	08-28-23

Invoice Charges

Ref Line No.	Description	Billing Date	No. Of Units	Unit of Measure	Unit Price	Charges/Credits
1	JPA# 22-0008725, T039201C Invoice for additional construction funds	08-28-23				\$987,163.00
Total Invoice Charges						\$987,163.00

Other Charges

Description	Date	Charges
Total Other Charges		

Credit Payments Applied	\$0.00
Total Amount Due	\$987,163.00

Additional Notes:

(See Attached JPA# 22-0008725)

Instructions

Please contact our office for payment and billing questions.

Contact:	(602) 712-7534	accountsreceivable@azdot.gov
LA - AR		

DETAILED ESTIMATE RECAPITULATION

0000 MA GUA T039201C
 GUA-0(206)T
 Highline Canal; Mineral Rd to Avenida Del Yaqui

CREATED: 8/21/2023
 REVISED: 8/28/2023
 ENGINEER: TMR

DESCRIPTION	FHWA CODE	ESTIMATED COST	FEDERAL PARTICIPATION	FEDERAL FUNDS 100.00%	LOCAL FUNDS 100.00%	LENGTH IN MI
Highline Canal Lighting	28	1,217,800	1,217,800	230,637	987,163	1.500
SUBTOTAL		1,217,800	1,217,800	230,637	987,163	
CONSTRUCTION ENGINEERING	Fixed 17	210,297	210,297	210,297		
CONSTRUCTION CONTINGENCY	5% 28	60,890	60,890	60,890		
PROJECT TOTAL:		1,488,987	1,488,987	501,824	987,163	1.500

NOTE:

ADOT CAR No.: IGA 22-0008725-I
 AG Contract No.: P0012022001735
 Project Location/Name: Highline Canal,
 Mineral Rd – Avenida Del Yaqui
 Type of Work: Replace Lighting System
 Federal-aid No.: GUA-0(206)T
 ADOT Project No.: T0392 01D/01C
 TIP/STIP No.: GDL21-240D,GDL23-240C
 CFDA No.: 20.205 - Highway Planning and
 Construction
 Budget Source Item No.: N/A

C2022-48

INTERGOVERNMENTAL AGREEMENT

BETWEEN
 THE STATE OF ARIZONA
 AND
 TOWN OF GUADALUPE

THIS AGREEMENT (“Agreement”) is entered into this date November 25, 2022, pursuant to the Arizona Revised Statutes (“A.R.S.”) §§ 11-951 through 11-954, as amended, between the STATE OF ARIZONA, acting by and through its DEPARTMENT OF TRANSPORTATION (the “State” or “ADOT”) and the TOWN OF GUADALUPE, acting by and through its MAYOR and TOWN COUNCIL (the “Town”). The State and the Town are each individually referred to as a “Party” and are collectively referred to as the “Parties.”

I. RECITALS

1. The State is empowered by A.R.S. § 28-401 to enter into this Agreement and has delegated to the undersigned the authority to execute this Agreement on behalf of the State.
2. The Town is empowered by A.R.S. § 9-240 to enter into this Agreement and has by resolution, a copy of which is attached and made a part of, resolved to enter into this Agreement and has authorized the undersigned to execute this Agreement on behalf of the Town.
3. The Town has received funding through the Fiscal Year (FY) 2022 Allocation of Highway Infrastructure Programs (HIP) Congressional Directed Spending Projects (Earmarks) for the work proposed under this Agreement consisting of removing the existing solar powered lighting system for 1.5 miles along the Highline Canal Multi-Use Pathway within the Town of Guadalupe, and replacing with an electric powered lighting system, (the “Project”). The Project cost, shown in Exhibit A, is estimated at \$579,299.00, which includes federal aid and the Town's match. The Town will administer the design and the State will advertise, bid and award, and administer the construction phase of the Project.
4. The interest of the State in this Project is the acquisition of federal funds for the use and benefit of the Town and authorization of such federal funds for the Project pursuant to federal law and regulations. The State shall be the designated agent for the Town for the

IGA 22-0008725-I

Project, if the Project is approved by Federal Highway Administration (FHWA) and funds for the Project are available.

THEREFORE, the Recitals set forth above and Exhibit A, attached hereto and made part hereof, are incorporated into this Agreement and in consideration of the mutual terms expressed herein, it is agreed as follows:

II. SCOPE OF WORK

1. The Parties agree:
 - a. The Project will be completed, accepted, and paid for in accordance with the requirements of the Project plans and specifications.
 - b. The final cost estimate may exceed the initial estimate identified in Exhibit A, and in such case, the Town is responsible for and agrees to pay, the difference prior to bid advertisement.
 - c. The final Project amount may exceed the initial estimate(s) identified in Exhibit A, and in such case, the Town is responsible for, and agrees to pay, any and all actual costs exceeding the initial estimate. If the final Project amount is less than the initial estimate, the difference between the final bid amount and the initial estimate will be de-obligated or otherwise released from the Project and returned to the FHWA. The Town acknowledges it remains responsible for actual costs and agrees to pay according to the terms of this Agreement.
 - d. The Project will be completed in accordance with the memorandum dated June 28, 2022 shown in Exhibit B, attached and made part of this Agreement.
 - e. A portion of the work will be performed within Salt River Project (SRP) right of way. The Town will coordinate with SRP as needed for items including but not limited to necessary reviews and permits.
 - f. The Town and ADOT will each separately file a Notice of Intent (NOI) under the Construction General Permit (CGP) with the Arizona Department of Environmental Quality (ADEQ) before construction begins, if applicable to the Project.
2. The State will:
 - a. Execute this Agreement, and if the Project is approved by FHWA and funds for the Project are available, be the Town's designated agent for the Project.
 - b. After this Agreement is executed, and prior to performing or authorizing any work on the Project, invoice the Town for the initial Project Development Administration (PDA) costs, estimated at \$30,000.00. If PDA costs exceed the estimate during the development of design, notify the Town, obtain concurrence prior to continuing with the development of design, and invoice as determined by ADOT and the Town for additional

IGA 22-0008725-I

costs to complete PDA for the Project. After the Project costs are finalized invoice or reimburse the Town for the difference between actual costs and the amount the Town has paid for PDA.

- c. After receipt of the PDA costs, review design plans, specifications, cost estimates and other such documents required for the construction bidding and construction of the Project, including scoping/design plans and documents required by FHWA to qualify projects for and to receive federal funds; provide design review comments to the Town as appropriate.
 - d. After completion of design review and prior to bid advertisement, invoice the Town for the actual PDA costs, as applicable, and the Town's share of the Project construction costs, estimated at \$47,475.00. After the Project costs for construction are finalized, the State will either invoice or reimburse the Town for the difference between estimated and actual costs. De-obligate or otherwise release any remaining federal funds from the scoping/design phase of the Project.
 - e. After receipt of the actual PDA costs, if applicable, and the Town's estimated share of the Project construction costs, including the difference between the final and the initial construction cost estimates, if applicable, submit all required documentation to FHWA with the recommendation that the maximum federal funds programmed for construction of this Project be approved. Should costs exceed the maximum federal funds available, it is understood and agreed that the Town will be responsible for any overage.
 - f. After receipt of FHWA authorization, proceed to advertise for, receive and open bids award and enter into a contract with the firm for the construction of the Project. If the bid amounts exceed the construction cost estimate, obtain Town concurrence and invoice the Town for the difference between the construction cost estimate and the bid amount prior to awarding the contract.
 - g. Notify the Town of completion and final acceptance of the Project. At such time, file a Notice of Termination (NOT) with ADEQ transferring CGP responsibilities to the Town, and provide a copy to the Town indicating that the State's maintenance responsibility of the Project is terminated, as applicable.
 - h. Notify the Town of completion and final acceptance of the Project; coordinate with the Town and turn over full responsibility of the Project improvements.
 - i. Not be obligated to maintain the Project, should the Town fail to budget or provide for proper and perpetual maintenance as set forth in this Agreement.
3. The Town will:
- a. Designate the State as the Town's authorized agent for the Project.
 - b. Within 30 days of receipt of an invoice from the State, pay the initial PDA costs, estimated at \$30,000.00. Agree to be responsible for actual PDA costs, if during the review of design, PDA costs exceed the initial estimate. Be responsible for the difference between the estimated and actual PDA and design costs of the Project.

IGA 22-0008725-I

- c. Prepare and provide design plans, specifications, cost estimates and other such documents required for the construction bidding and construction of the Project, including scoping/design plans and documents required by FHWA to qualify projects for and to receive federal funds; incorporate design review comments from the State, as appropriate.
- d. Enter into an agreement with the design consultant which states that the design consultant will provide professional post-design services as required and requested throughout and at completion of the construction phase of the Project. After final acceptance of the Project, provide an electronic version of the record drawings to the ADOT Project Manager.
- e. After completion of design, within 30 days of receipt of an invoice from the State and prior to bid advertisement, pay to the State any outstanding PDA costs, the Town's share of the Project construction costs, estimated at \$47,475.00, and if applicable, the difference between the final and initial construction cost estimates. Be responsible for and pay the difference between the estimated construction cost and Project bid amount prior to award. After Project completion, be responsible for and pay any outstanding Project costs, within 30 days of receipt of an invoice.
- f. Be responsible for all costs incurred in performing and accomplishing the work as set forth under this Agreement, that are not covered by federal funding. Should costs be deemed ineligible or exceed the maximum federal funds available, it is understood and agreed that the Town is responsible for these costs; payment for these costs shall be made within 30 days of receipt of an invoice from the State.
- g. Certify that all necessary rights of way have been or will be acquired prior to advertisement for bid and also certify that all obstructions or unauthorized encroachments of whatever nature, either above or below the surface of the Project area, shall be removed from the proposed right of way, or will be removed prior to the start of construction, in accordance with The Uniform Relocation Assistance and Real Property Acquisition Policies Act of 1970 as amended; 49 CFR 24.102 Basic Acquisition Policies; 49 CFR 24.4 Assurances, Monitoring and Corrective Action, parts (a) & (b) and ADOT Right of Way Procedures Manual: 8.02 Responsibilities, 8.03 Prime Functions, 9.06 Monitoring Process and 9.07 Certification of Compliance. Coordinate with the appropriate State's Right of Way personnel during any right of way process performed by the Town, if applicable.
- h. As applicable, certify that the Town has adequate resources to discharge the Town's real property related responsibilities and ensures that its Title 23-funded projects are carried out using the FHWA approved and certified ADOT Right of Way Procedures Manual and that they will comply with current FHWA requirements whether or not the requirements are included in the FHWA approved ADOT Right of Way Procedures Manual. (23 CFR 710.201)
- i. Not permit or allow any encroachments on or private use of the right of way, except those authorized by permit. In the event of any unauthorized encroachment or improper use, the Town shall take all necessary steps to remove or prevent any such

IGA 22-0008725-I

encroachment or use. Provide a copy of encroachment permits issued within the Project limits to the State.

- j. Automatically grant to the State, by execution of this Agreement, its agents and/or contractors, without cost, the temporary right to enter Town rights of way, as required, to conduct any and all construction and preconstruction related activities for the Project, on, to and over said Town rights of way. This temporary right will expire with completion of the Project.
- k. Investigate and document utilities within the Project limits; submit findings to ADOT determining prior rights or no prior rights; approve an easement within the final right of way to re-establish the prior right location for those utilities with prior rights.
- l. Be obligated to incur any expenditure should unforeseen conditions or circumstances increase Project costs. Be responsible for the cost of any Town requested changes to the scope of work of the Project, such changes will require State and FHWA approval. Be responsible for any contractor claims for additional compensation caused by Project delay attributable to the Town. Payment for these costs will be made to the State within 30 days of receipt of an invoice from the State.
- m. After notification of final acceptance by the State, assume and maintain full responsibility of the Project, including Storm Water Pollution Prevention Plans (SWPPP) inspections, maintenance, and required documentation, until final stabilization is reached. Provide the NOI number to the State and the Contractor, accept CGP responsibilities at time of transfer, and file an NOT with ADEQ when final stabilization is reached, as applicable.
- n. After completion and final acceptance of the Project, agree to maintain and assume full responsibility of the Project and all Project components.

III. MISCELLANEOUS PROVISIONS

1. **Effective Date.** This Agreement shall become effective upon signing and dating of all Parties.
2. **Amendments.** Any change or modification to the Project will only occur with the mutual written consent of both Parties.
3. **Duration.** The terms, conditions and provisions of this Agreement shall remain in full force and effect until completion of the Project and all related deposits and/or reimbursements are made. Any and all obligations of maintenance hereunder shall remain perpetual and shall survive any termination hereof and the assignment or assumption of this Agreement or the Project by another competent jurisdiction or entity.

Cancellation. This Agreement may be cancelled at any time up to 30 days before the award of the Project contract, so long as the cancelling Party provides at least 30 days' prior written notice to the other Party. It is understood and agreed that, in the event the Town terminates this Agreement, the Town shall be responsible for all costs incurred by the State up to the time of termination. It is further understood and agreed that in the event the Town

IGA 22-0008725-I

terminates this Agreement, the State shall in no way be obligated to complete or maintain the Project.

4. **Indemnification.** The Town shall indemnify, defend, and hold harmless the State, any of its departments, agencies, officers or employees (collectively referred to in this paragraph as the "State") from any and all claims, demands, suits, actions, proceedings, loss, cost and damages of every kind and description, including reasonable attorneys' fees and/or litigation expenses (collectively referred to in this paragraph as the "Claims"), which may be brought or made against or incurred by the State on account of loss of or damage to any property or for injuries to or death of any person, to the extent caused by, arising out of, or contributed to, by reasons of any alleged act, omission, professional error, fault, mistake, or negligence of the Town, its employees, officers, directors, agents, representatives, or contractors, their employees, agents, or representatives in connection with or incident to the performance of this Agreement. The Town's obligations under this paragraph shall not extend to any Claims to the extent caused by the negligence of the State, except the obligation does apply to any negligence of the Town which may be legally imputed to the State by virtue of the State's ownership or possession of land. The Town's obligations under this paragraph shall survive the termination of this Agreement.
5. **Third-Party Indemnification.** The State shall include Section 107.13 of the 2021 version of the Arizona Department of Transportation Standard Specifications for Road and Bridge Construction, incorporated into this Agreement by reference, in the State's contract with any and all contractors, of which the Town shall be specifically named as a third-party beneficiary. This provision may not be amended without the approval of the Town.
6. **Programmed Federal Funds.** The cost of Project work under this Agreement is to be covered by the federal funds programmed for this Project, up to the maximum available. The Town acknowledges that actual Project costs may exceed the maximum available amount of federal funds, or that certain costs may not be accepted by FHWA as eligible for federal funds. Therefore, the Town agrees to pay the difference between actual costs of the Project and the federal funds received.
7. **Termination of Federal Funding.** Should the federal funding related to this Project be terminated or reduced by the federal government, or Congress rescinds, fails to renew, or otherwise reduces apportionments or obligation authority, the State shall in no way be obligated for funding or liable for any past, current or future expenses under this Agreement.
8. **Indirect Costs.** The cost of the Project under this Agreement includes indirect costs approved by FHWA, as applicable.
9. **Federal Funding Accountability and Transparency Act.** The Parties warrant compliance with the Federal Funding Accountability and Transparency Act of 2006 and associated 2008 Amendments (the "Act"). Additionally, in a timely manner, the Town will provide information that is requested by the State to enable the State to comply with the requirements of the Act, as may be applicable.
10. **Title VI.** The Town acknowledges and will comply with Title VI of the Civil Rights Act Of 1964.

IGA 22-0008725-1

11. Governing Law. This Agreement shall be governed by and construed in accordance with Arizona laws.
12. Conflicts of Interest. This Agreement may be cancelled in accordance with A.R.S. § 38-511.
13. Inspection and Audit. The Town shall retain all books, accounts, reports, files and other records relating to this Agreement which shall be subject at all reasonable times to inspection and audit by the State for five years after completion of the Project. Such records shall be produced by the Town, electronically or at the State office as set forth in this Agreement, at the request of ADOT.
14. Non-Discrimination. This Agreement is subject to all applicable provisions of the Americans with Disabilities Act (Public Law 101-336, 42 U.S.C. 12101-12213) and all applicable federal regulations under the Act, including 28 CFR Parts 35 and 36. The Parties to this Agreement shall comply with Executive Order Number 2009-09 issued by the Governor of the State of Arizona and incorporated in this Agreement by reference regarding "Non-Discrimination."
15. Non-Availability of Funds. Every obligation of the State under this Agreement is conditioned upon the availability of funds appropriated or allocated for the fulfillment of such obligations. If funds are not allocated and available for the continuance of this Agreement, this Agreement may be terminated by the State at the end of the period for which the funds are available. No liability shall accrue to the State in the event this provision is exercised, and the State shall not be obligated or liable for any future payments as a result of termination under this paragraph.
16. Arbitration. In the event of any controversy, which may arise out of this Agreement, the Parties agree to abide by arbitration as is set forth for public works contracts if required by A.R.S. § 12-1518.
17. E-Verify. The Parties shall comply with the applicable requirements of A.R.S. § 41-4401.
18. Anti-Israel Boycott Act and Certification of No Use of Forced Labor of Ethnic Uyghurs in the People's Republic of China. The Parties shall certify that all contractors comply with the applicable requirements of A.R.S. § 35-393.01 and A.R.S. § 35-394.
19. Other Applicable Laws. The Parties shall comply with all applicable laws, rules, regulations and ordinances, as may be amended.
20. Notices. All notices or demands upon any Party to this Agreement shall be in writing and shall be delivered electronically, in person, or sent by mail, addressed as follows:

For Agreement Administration:

Arizona Department of Transportation
 Joint Project Agreement Group
 205 S. 17th Avenue, Mail Drop 637E
 Phoenix, AZ 85007
JPABranch@azdot.gov

Town of Guadalupe
 Jeff Kulaga
 9241 S Avenida del Yaqui
 Guadalupe, AZ 85283
 480.505.5376
jkulaga@guadalupeaz.org

For Project Administration:

Arizona Department of Transportation

Town of Guadalupe
 Jeff Kulaga

IGA 22-0008725-I

Project Management Group
205 S. 17th Avenue, Mail Drop 614E
Phoenix, AZ 85007
PMG@azdot.gov

9241 S Avenida del Yaqui
Guadalupe, AZ 85283
480.505.5376
jkulaga@guadalupeaz.org

For Financial Administration:

Arizona Department of Transportation
Project Management Group
205 S. 17th Avenue, Mail Drop 614E
Phoenix, AZ 85007
PMG@azdot.gov

Town of Guadalupe
Jeff Kulaga
9241 S Avenida del Yaqui
Guadalupe, AZ 85283
480.505.5376
jkulaga@guadalupeaz.org

21. **Revisions to Contacts.** Any revisions to the names and addresses above may be updated administratively by either Party and shall be in writing.
 22. **Legal Counsel Approval.** In accordance with A.R.S. § 11-952 (D), the written determination of each Party's legal counsel providing that the Parties are authorized under the laws of this State to enter into this Agreement and that the Agreement is in proper form is set forth below.
 23. **Electronic Signatures.** This Agreement may be signed in an electronic format using DocuSign.
-

Remainder of this page is intentionally left blank.

(Signatures begin on the next page)

IGA 22-0008725-I

IN WITNESS WHEREOF, the Parties have executed this Agreement to be effective upon the full completion of signing and dating by all Parties to this Agreement.

TOWN OF GUADALUPE

By  Date: November 10, 2022
VALERIE MOLINA
Mayor

ATTEST:

By  Date: November 10, 2022
JEFF KULAGA
Town Manager/Clerk

I have reviewed the above referenced Intergovernmental Agreement between the State of Arizona, acting by and through its DEPARTMENT OF TRANSPORTATION, and the TOWN OF GUADALUPE, an agreement among public agencies which, has been reviewed pursuant to A.R.S. §§ 11-951 through 11-954 and A.R.S. § 9-240 and declare this Agreement to be in proper form and within the powers and authority granted to the Town under the laws of the State of Arizona.

No opinion is expressed as to the authority of the State to enter into this Agreement. Approved as to Form:

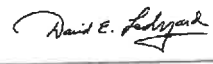
By  Date: November 10, 2022
David E. Ledyard, Esq.
Faith, Ledyard & Faith
Town Attorney's

IGA 22-0008725-I

ARIZONA DEPARTMENT OF TRANSPORTATION

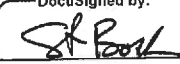
DocuSigned by:
 By  Date 11/23/2022
STEVE BOSCHEN, PE
 Infrastructure Delivery and Operations Division
 Division Director

A.G. Contract No. P0012022001735 (ADOT IGA 22-0008725-I), an Agreement between public agencies, the State of Arizona and Town of Guadalupe, has been reviewed pursuant to A.R.S. §§ 11-951 through 11-954 and A.R.S. § 28-401, by the undersigned Assistant Attorney General who has determined that it is in the proper form and is within the powers and authority granted to the State of Arizona. No opinion is expressed as to the authority of the remaining Parties, other than the State or its agencies, to enter into said Agreement.

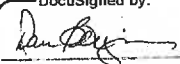
DocuSigned by:
 By  Date 11/25/2022
 Assistant Attorney General

IGA 22-0008725-I

EXHIBIT A
Cost Estimate

T0392 01D/01C

The Project costs are estimated as follows:

ADOT Project Development Administration (PDA) Cost, non-federal-aid:

Town's costs @ 100%	\$30,000.00
---------------------	-------------

Construction:*

Federal-aid funds	\$ 501,824.00
Town's match	\$ 47,475.00

Subtotal – Construction	\$ 549,299.00
--------------------------------	----------------------

Estimated TOTAL Project Cost	\$579,299.00
-------------------------------------	---------------------

Total Estimated Town Funds	\$ 77,475.00
-----------------------------------	---------------------

Total Federal Funds	\$ 501,824.00
----------------------------	----------------------

* (Includes 15% construction engineering (CE) and administration cost (this percentage is subject to change, any change will require concurrence from the Town) and 5% Project contingencies)