



**REVISED**

**\*\*\*DUE TO COVID-19, SEATING CAPACITY IS LIMITED TO NO MORE THAN 10 ATTENDEES\*\*\***

**\*\*\*MEETING BROADCAST LIVE ON TOWN OF GUADALUPE FACEBOOK PAGE\*\*\***

**NOTICE OF REGULAR MEETING  
OF THE GUADALUPE TOWN COUNCIL**

**THURSDAY, FEBRUARY 25, 2021**

**6:00 P.M.**

**GUADALUPE TOWN HALL  
9241 SOUTH AVENIDA DEL YAQUI, MUSEUM ROOM  
GUADALUPE, ARIZONA**

Valerie Molina  
Mayor

Ricardo Vital  
Vice Mayor

Mary Bravo  
Councilmember

Gloria Cota  
Councilmember

Elvira Osuna  
Councilmember

Joe Sánchez  
Councilmember

Anita Cota Soto  
Councilmember

Agendas/Minutes:  
[www.guadalupeaz.org](http://www.guadalupeaz.org)

Town Council Chambers  
9241 S. Avenida del Yaqui  
Guadalupe, AZ 85283  
Phone: (480) 730-3080  
Fax: (480)-505-5368

Pursuant to A.R.S. 38-431.02, notice is hereby given to the members of the Town of Guadalupe Council and to the general public that the Guadalupe Town Council will hold a meeting, open to the public, on Thursday, February 25, 2021, at 6:00 P.M., at Guadalupe Town Hall, 9241 South Avenida del Yaqui, Museum Room, Guadalupe, Arizona.

**AGENDA**

- A. CALL TO ORDER
- B. ROLL CALL
- C. INVOCATION/PLEDGE OF ALLEGIANCE
- D. APPROVAL OF MINUTES
  - 1. Approval of the February 11, 2021, Town Council Regular Meeting Minutes.
- E. CALL TO THE PUBLIC: An opportunity is provided to the public to address the Council on items that are not on the agenda or included on the consent agenda. A total of 3 minutes will be provided for the Call to the Audience agenda item, unless the Council requests an exception to this limit. Please note that those wishing to comment on agenda items posted for action will be provided the opportunity at the time the item is heard.
- F. MAYOR and COUNCIL PRESENTATIONS:
- G. DISCUSSION AND POSSIBLE ACTION ITEMS:
  - 1. **EMERGENCY PROPERTY CLEAN UP PROCLAMATION:** The Mayor will present a Proclamation declaring that an emergency exists at the Property located at 8427 South Calle Batoua which constitutes an extreme health hazard requiring immediate and decisive emergency action to remedy; and, to authorize the Town Manager / Clerk to take any legal means necessary to clean and clear the Property in order to remedy the emergency situation. Council may provide direction to the Town Manager / Clerk.



Valerie Molina  
Mayor

Ricardo Vital  
Vice Mayor

Mary Bravo  
Councilmember

Gloria Cota  
Councilmember

Elvira Osuna  
Councilmember

Joe Sánchez  
Councilmember

Anita Cota Soto  
Councilmember

Agendas/Minutes:  
[www.guadalupeaz.org](http://www.guadalupeaz.org)

Town Council Chambers  
9241 S. Avenida del Yaqui  
Guadalupe, AZ 85283  
Phone: (480) 730-3080  
Fax: (480)-505-5368

**2. PUBLIC HEARING – RECREATIONAL MARIJUANA ORDINANCE (ORDINANCE NO. O2021.01):** Hold a public hearing to receive public input to amend the Town Code of Ordinances, Chapter 154 Zoning, by adding a new subchapter titled Recreational Marijuana Sections § 154.086 – § 154.090. The proposed ordinance regulates recreational marijuana and contains the following: establishing a purpose setting forth definitions; prohibiting marijuana on public property; prohibiting recreational marijuana establishments and marijuana testing facilities; providing for the repeal of conflicting ordinances; setting forth violations; providing for enforcement and penalties; providing for exemptions; providing for severability; and setting an effective date. Council may provide direction to the Town Manager / Clerk. *(related to #3)*

**3. RECREATIONAL MARIJUANA ORDINANCE (ORDINANCE NO. O2021.01):** Council will consider and may take action to adopt Ordinance No. O2021.01 amending the Town Code of Ordinances, Chapter 154 Zoning, by adding a new subchapter titled Recreational Marijuana Sections § 154.086 – § 154.090. The proposed ordinance regulates recreational marijuana and contains the following: establishing a purpose setting forth definitions; prohibiting marijuana on public property; prohibiting recreational marijuana establishments and marijuana testing facilities; providing for the repeal of conflicting ordinances; setting forth violations; providing for enforcement and penalties; providing for exemptions; providing for severability; and setting an effective date. Council may provide direction to the Town Manager / Clerk. *(related to #2)*

**4. FY 2020/2021 MID-YEAR BUDGET STATUS REPORT:** Staff will present the mid-year, fiscal year (FY) 2020/21 (July 2020 – December 2020) financial status report that includes Town General Fund, Special funds and enterprise fund balances, and year to date revenues and expenditures. Council may provide direction to the Town Manager / Clerk.

**5. COVID-19 ACTION UPDATE:** Mayor and Council will receive an update from Town staff regarding current steps taken to safe guard public health and safety in response to the Coronavirus and its impact to Town services. Council may provide direction to the Town Manager / Clerk. *Material for this agenda item will be provided at the meeting.*

**6. AVENIDA DEL YAQUI STREET IMPROVEMENT PROJECT UPDATE:** Mayor and Council will receive an update of the Avenida del Yaqui improvement project. The Avenida del Yaqui improvement project will resurface the roadway pavement, install new curb and gutter, sidewalks, driveways and striped bicycle facilities (designated bicycle lanes), new traffic control signs and enhanced pedestrian crosswalks. The project cost is estimated at \$5.6 million with \$5.3 million funded through federal transportation dollars and the remaining \$319,000 funded by the Town of Guadalupe. Construction is anticipated to begin in September, 2021. Council may provide direction to the Town Manager / Clerk.

**7. AVENIDA DEL YAQUI STREET IMPROVEMENT PROJECT INTERGOVERNMENTAL AGREEMENT AMENDMENT NO. 1:** Council will consider and may take action to approve Amendment No. 1 (C2019-12A) to an intergovernmental agreement 19-0007278-I with the State of Arizona, acting through its Department of Transportation (ADOT) for the purpose of revising project costs as a result of the Town of Guadalupe receiving an additional \$2,269,226 in federal funding for the Avenida del Yaqui Street Improvement Project; and, authorizes the Mayor to execute all documents in furtherance of this agreement amendment. The revised project costs are as follows: Estimated total project cost: \$5,601,520; of which Federal Funds total: \$5,282,233 and Town funds; total \$319,287. Council may provide direction to the Town Manager / Clerk.



Valerie Molina  
Mayor

Ricardo Vital  
Vice Mayor

Mary Bravo  
Councilmember

Gloria Cota  
Councilmember

Elvira Osuna  
Councilmember

Joe Sánchez  
Councilmember

Anita Cota Soto  
Councilmember

Agendas/Minutes:  
[www.guadalupeaz.org](http://www.guadalupeaz.org)

Town Council Chambers  
9241 S. Avenida del Yaqui  
Guadalupe, AZ 85283  
Phone: (480) 730-3080  
Fax: (480)-505-5368

**8. AUDIT SERVICES REQUEST FOR PROPOSALS REQUEST:** Mayor and Council will consider and may approve the staff recommendation to issue a Request for Proposals for internal audit services. Council may provide direction to the Town Manager / Clerk.

**9. CHIEF FISCAL OFFICER DESIGNATION (RESOLUTION NO. R2021.01):** Council will consider and may take action to adopt a resolution designating the Town Manager/Clerk as the Chief Fiscal Officer. The Chief Fiscal Officer is responsible for officially submitting the Fiscal Year 2022 Expenditure Limitation Report to the Auditor General. Council may provide direction to the Town Manager / Clerk.

**10. SCHEDULED PUBLIC APPEARANCE:** Lindsey Wilcox, Crisis Response Network (CRN) representative, will be addressing the Mayor and Council on issues related to providing social services to the Town of Guadalupe. Council may provide direction to the Town Manager / Clerk. *(there is no material for this agenda item)*

**11. STOTTLEMYRE PARK SCOREBOARD REPLACEMENT:** Mayor and Council will receive an update of the Stottlemyre Park Little League scoreboard project. The Arizona Diamondbacks and Arizona Public Service (APS) have partnered to fund replacement of the scoreboard at an estimated cost of \$30,000. Council may provide direction to the Town Manager / Clerk.

H. TOWN MANAGERS' COMMENTS

I. COUNCILMEMBERS' COMMENTS

J. ADJOURNMENT



February 19, 2021

**REVISED**

To: The Honorable Mayor and Town Council

From: Jeff Kulaga, Town Manager / Clerk

**RE: February 25, 2021, Town Council Regular Meeting Information Report**

---

The purpose of this report is to provide brief information regarding each of the meeting's agenda items.

**Agenda Items:**

**D1. FEBRUARY 11, 2021, REGULAR COUNCIL MEETING MINUTES. (PAGES 7 – 14)**

**G1. REVISED – EMERGENCY PROPERTY CLEAN UP PROCLAMATION (PAGE 15):** The property owner of record for the property located at 8427 SOUTH CALLE BATOUA is Tomas Villegas, who is deceased. Town staff have been unable to locate heirs or anyone who claims ownership, responsibility and or control of the property. This property poses a health and safety threat to the community. The condition of the property is dangerous, unsightly, littered with debris, garbage/refuse, broken glass, used hypodermic needles, human feces, and other trash and debris. Approval of the Proclamation will authorize the Town Manager / Clerk to take any legal means necessary to clean and clear the Property in order to remedy the emergency situation.

**G2 & G3: PUBLIC HEARING – RECREATIONAL MARIJUANA ORDINANCE (ORDINANCE NO. O2021.01) (PAGES 16 – 22):** Ordinance No. O2021.01 amends the Town Code of Ordinances by adding provisions for the regulation of recreational marijuana. On November 3, 2020, Arizona voters passed Proposition 207, the Smart and Save Arizona Act, authorizing the possession, consumption, purchase, processing, manufacturing or transporting of marijuana by an individual who is at least twenty-one (21) years of age; allowing a nonprofit medical marijuana dispensary or other non-dispensary applicant to apply to the Department of Health Services to become a licensed marijuana establishment authorized to engage in the retail sale, cultivation, and manufacturing of marijuana; and, allowing the Department, or another entity designated by the Department, to become a marijuana testing facility to test the potency of marijuana and detect any harmful contaminants.

**G4. FISCAL YEAR 2020/21 MID-YEAR BUDGET STATUS REPORT (PAGES 23 – 47):** This fiscal year (FY) 2020/21 mid-year report, presented by staff, provides an overview of current year revenue and expenditures and the actual revenues and expenditures for FY 2020/21 as a percentage of the adopted budget for the entire year. To that end, the target is 50% in revenues and equally 50% in expenses at the mid-year point. The attached memorandum and accompanying PowerPoint provides a mid-year analysis of Town funds. The PowerPoint will be presented at the February 25<sup>th</sup> Council meeting.

Town Funds presented:

- General Fund
- Special Funds:
  - Highway User Revenue Fund (HURF)
  - Local Transportation Assistance Fund (LTAF)
  - Senior Center
  - Community Action Program (CAP)
  - Municipal Property Corporation Bond
- Community Action on Program
- Pascua Yaqui Tribe: Coronavirus Aid, Relief, and Economic Security (CARES) Act
- State of Arizona: Coronavirus Aid, Relief, and Economic Security (CARES) Act
- Enterprise Funds:
  - Mercado
  - Wastewater / Sewer
  - Solid Waste / Refuse

**G5. COVID-19 UPDATE (MATERIAL TO BE PRESENTED AT THE MEETING):** Staff will provide an update of current Town of Guadalupe COVID-19 conditions as provided by Maricopa County Health Services, and any currently available vaccine information presented via a PowerPoint presentation at the meeting.

**G6. AVENIDA DEL YAQUI STREET IMPROVEMENT PROJECT UPDATE (PAGES 48 – 71):** Staff will provide an update of the Avenida del Yaqui street improvement project. On May 30, 2019, Council adopted Resolution No. R2019.07 and approved an intergovernmental agreement (C2019-12) with the State of Arizona, acting through its Department of Transportation (ADOT) for the purpose of revising project costs for the design and construction of sidewalks and bike lanes on Avenida del Yaqui, northbound and southbound, between Highland Canal and Calle Carmen. The project includes mill and overlay of the full roadway cross section of existing pavement and complete reconstruction of the concrete curb, gutter and sidewalk along both sides of the corridor, new pavement markings and enhanced pedestrian crossings. The project cost is estimated at \$5.6 million with \$5.3 million funded through federal transportation dollars and the remaining \$319,000 funded by the Town of Guadalupe. Construction is anticipated to begin in September, 2021.

**G7. AVENIDA DEL YAQUI STREET IMPROVEMENT PROJECT, CONTRACT AMENDMENT NO. 1 (PAGES 72 – 87):** The purpose of Amendment No. 1 (C2019-12A) is to revise project costs as a result of the Town of Guadalupe receiving an additional \$2,269,226 in federal funds for the Avenida del Yaqui street improvement project. As follows, the total project cost is estimated at \$5,601,520 with federal funds accounting for 94.3% of the total costs and the Town’s responsibility of 5.7% of costs.

Federal funds will be used for the ADOT Project Development Administration (PDA), scoping/design, and construction of the Project, including the construction engineering (CE) and administration cost. The estimated Project costs are as follows:

<b><u>PDA/ Scoping/Design:</u></b>	
Federal-aid funds @ 94.3%	\$ 565,800
Town’s match @ 5.7%	\$ 34,200
<b>Subtotal – PDA/Scoping/Design</b>	<b>\$ 600,000</b>
<b><u>Construction:</u></b>	
Federal-aid funds @ 94.3%	\$ 4,716,433
Town’s match @ 5.7%	\$ 285,087
<b>Subtotal – Construction*</b>	<b>\$ 5,001,520</b>
<b>Estimated TOTAL Project Cost</b>	<b>\$ 5,601,520</b>
<b>Total Federal Funds</b>	<b>\$ 5,282,233</b>
<b>Total Estimated Town Funds</b>	<b>\$ 319,287</b>

\* (Includes 15% CE (this percentage is subject to change, any change will require concurrence from the Town) and 5% Project contingencies)

As background, on May 30, 2019, Council adopted Resolution No. R2019.07 and approved an intergovernmental agreement (IGA) (C2019-12) with the State of Arizona, acting through its Department of Transportation (ADOT) for the purpose of initiating the Avenida del Yaqui federally funded street improvement project. As outlined in the IGA, the project scope includes the design and construction of sidewalks and bike lanes on Avenida del Yaqui, northbound and southbound, between Highland Canal and Calle Carmen, (the “Project”). The Project includes mill and overlay of the full roadway cross section of existing pavement and complete reconstruction of the concrete curb, gutter and sidewalk along both sides of the corridor. The corridor improvement also includes new pavement markings, added bicycle lanes, and enhanced pedestrian crossings. The Project includes removal and replacement of all existing traffic control signs along the length of the Project boundary.

**G8. AUDIT SERVICES REQUEST FOR PROPOSALS (PAGES 88 – 99):** Staff is recommending that a Request for Proposals be issued for municipal internal audit services. The current internal audit service provider is Colby & Powell, PLC, who were originally contracted with the Town to provide these services in 2004. While Colby & Powell, PLC has served the Town well, a competitive process for services is warranted based on 17 years since selecting Colby & Powell, PLC.

The Government Finance Officers Association (GFOA) recommends that municipalities conduct internal audits to assist management in maintaining a comprehensive framework of internal controls. Internal auditing is included in governmental best practices. The purpose of municipal audits is to guide leadership in developing policies and procedures, training and retraining staff, and holding staff accountable, in order to provide the Council with the most accurate and comprehensive information to make better business decisions.

**G9. CHIEF FISCAL OFFICER DESIGNATION (RESOLUTION NO. R2021.01) (PAGE 100):** Annually, the Auditor General's Office requires municipalities to designate a Chief Fiscal Officer within each organization. Resolution No. R2021.01 designates the Town Manager / Clerk as the Towns' Chief Fiscal Officer who is responsible for submitting the Fiscal Year 2022 Expenditure Limitation Report to the Auditor General's Office.

**G10. SCHEDULED PUBLIC APPEARANCE (NO MATERIAL FOR THIS ITEM):** Lindsey Wilcox, Crisis Response Network representative, will provide an update regarding ongoing activities related to providing social services to Town of Guadalupe community members.

**G11. STOTTLEMYRE PARK SCOREBOARD REPLACEMENT (PAGES 101—104):** The Stottlemyre Park Little League scoreboard is presently being replaced with a brand new scoreboard. The existing scoreboard was in disrepair, not operating properly, and replacements parts were difficult to find. The Arizona Diamondbacks and APS have partnered to fund the replacement of the scoreboard with estimated cost at \$30,000.



# Minutes Town Council Regular Meeting February 11, 2021

Valerie Molina  
Mayor

Ricardo Vital  
Vice Mayor

Mary Bravo  
Councilmember

Gloria Cota  
Councilmember

Elvira Osuna  
Councilmember

Joe Sánchez  
Councilmember

Anita Cota Soto  
Councilmember

Agendas/Minutes:  
[www.guadalupeaz.org](http://www.guadalupeaz.org)

Town Council Chambers  
9241 S. Avenida del Yaqui  
Guadalupe, AZ 85283  
Phone: (480) 730-3080  
Fax: (480)-505-5368

Minutes of the Guadalupe Town Council Regular Meeting held on Thursday, February 11, 2021, at 6:00 P.M., at Guadalupe Town Hall, 9241 South Avenida del Yaqui, Museum Room, Guadalupe, Arizona.

A. Mayor Molina called the meeting to order at 6:05 p.m.

B. ROLL CALL

Councilmembers Present: Mayor Valerie Molina. The following councilmembers participated via video conference: Vice Mayor Ricardo Vital, Councilmember Mary Bravo, Councilmember Elvira Osuna, and Councilmember Joe Sánchez

Councilmembers Absent: Councilmember Gloria Cota and Councilmember Anita Cota Soto

Staff Present: Jeff Kulaga – Town Manager / Clerk and Jennifer Drury – Assistant to the Town Manager; Cachi Castorena, MCSO Deputy, and, David Ledyard – Town Attorney via video conference.

C. INVOCATION/PLEDGE OF ALLEGIANCE

Councilmember Bravo provided the invocation. Mayor Molina then led the Pledge of Allegiance.

D. APPROVAL OF MINUTES

1. Approval of the January 28, 2021, Town Council Regular Meeting Minutes.

**Motion by Vice Mayor Vital to approve agenda item D1; second by Councilmember Bravo. Motion passed unanimously on a voice vote 5-0.**

1. Approved the January 28, 2021, Town Council Regular Meeting Minutes.

E. CALL TO THE PUBLIC:

Lindsey Wilcox, Crisis Response Network (CRN) representative, stated that she serves as a Community Impact Liaison for the CRN. CRN is a grant funded organization that provides services free of charge. CRN is assisting the Guadalupe community by providing on-site resources for various community benefits such as food stamps, medical services, fresh produce.

Mayor Molina announced that Town Hall is open during Council meetings and invited community members to participate in the Call to the Public.

F. MAYOR and COUNCIL PRESENTATIONS:

Mayor Molina read a Proclamation declaring February 11, 2021 Maria Munoz Day in the Town of Guadalupe, Arizona.



Valerie Molina  
Mayor

Ricardo Vital  
Vice Mayor

Mary Bravo  
Councilmember

Gloria Cota  
Councilmember

Elvira Osuna  
Councilmember

Joe Sánchez  
Councilmember

Anita Cota Soto  
Councilmember

Agendas/Minutes:  
[www.guadalupeaz.org](http://www.guadalupeaz.org)

Town Council Chambers  
9241 S. Avenida del Yaqui  
Guadalupe, AZ 85283  
Phone: (480) 730-3080  
Fax: (480)-505-5368

## G. DISCUSSION AND POSSIBLE ACTION ITEMS:

### 1. INTERNAL AUDIT REPORT

Jeff Kulaga, Town Manager / Clerk, introduced from Matt Bingham of Colby & Powell, PLC, (Colby & Powell) Certified Public Accountants, who provided a presentation of the Town of Guadalupe audit report.

Mr. Bingham stated that the fiscal year for the Town audit report under consideration is from July 1, 2019 to June 30, 2020. This is the timeframe that the Town financial statements were audited. The auditor's opinion relates to whether or not the data in the financial statements and disclosures are materially correct, accurate, and complete. Colby & Powell follows federal government auditing standards for all entities that receive federal funding. Colby & Powell conducts a risk based approach to assess processes and internal controls; and, is required to report weaknesses found regarding internal processes and controls. No significant deficiencies or material weaknesses were found during this audit period.

Mr. Bingham noted that contributions to the Arizona State Retirement System (ASRS) have risen approximately \$80,000 compared to the last fiscal year. Of concern is the unfunded Arizona Public Safety Personnel Retirement System (PSPRS) pension fund, which will need to be paid in future years.

Mr. Bingham reviewed the Town's restricted and unrestricted net position – cash/receivables that must be spent on certain items versus cash/receivables that can be spent more flexibly. There is a downward trend in business activities, which should preferably be trending up to address future infrastructure repairs and replacements.

In response to a question regarding the difference in fund balances between the last fiscal year and this fiscal year's budget for the Solid Waste, Sewer, and Mercado, Mr. Kulaga noted that the rates for solid waste collection were raised to address funding shortfalls; funding was needed for urgent sewer repairs which impacted the fund balance. The Mercado fund is suffering due to lack of events held at this venue, business revenue shortfalls due to COVID-19, and businesses leaving or that are delinquent in rent. The Mercado is aging and will require future repairs.

### 2. COVID-19 ACTION UPDATE

Jeff Kulaga, Town Manager / Clerk, provided an update regarding current Town of Guadalupe COVID-19 positive case rates, scheduled testing events, vaccination information, and steps taken to safe guard public health and safety in response to the Coronavirus. On Saturday, February 13, 2021, the Pascua Yaqui Tribe will be offering free flu shots and free COVID-19 tests for Guadalupe residents. Vaccinations will not be available at this event.

Mr. Kulaga reviewed that statistics regarding the number of vaccinations that have been allocated statewide, with specifics regarding the number of vaccinations to date in Maricopa and Pima counties. He then reviewed the phases and categories of individuals that are eligible to receive a vaccine. There is additional information on the Arizona Department of Health Services website related to instructions on how to book vaccinations. The Town Promotoras are available via telephone to assist community members in scheduling vaccinations.

Mr. Kulaga reviewed the weekly positive case rates in Guadalupe and credited the positive downward trend on Guadalupe case rates on the efforts of the Towns' community partners.

In response to a question, Vice Mayor Vital stated that the number of people being tested for COVID-19 is decreasing. The Pascua Yaqui Tribe is working with Native Health and the Arizona Department of Health Services to provide homebound vaccinations.





Valerie Molina  
Mayor

Ricardo Vital  
Vice Mayor

Mary Bravo  
Councilmember

Gloria Cota  
Councilmember

Elvira Osuna  
Councilmember

Joe Sánchez  
Councilmember

Anita Cota Soto  
Councilmember

Agendas/Minutes:  
[www.guadalupeaz.org](http://www.guadalupeaz.org)

Town Council Chambers  
9241 S. Avenida del Yaqui  
Guadalupe, AZ 85283  
Phone: (480) 730-3080  
Fax: (480)-505-5368

Councilmembers noted that the Town is not issuing party permits and cautioned everyone about large gatherings during Lent. Residents are encouraged to get vaccinated and to continue wearing masks. Homebound vaccinations are available to anyone that is registered with Native Health. Mr. Kulaga noted that the Town is not tracking the number of deaths in Guadalupe that are attributed to COVID-19.

**3. SOLID WASTE COLLECTION SERVICE PROPOSED RATE INCREASE INTRODUCTION**

Jeff Kulaga, Town Manager / Clerk, provided a solid waste services financial status report and rate analysis including current financials, five year projected revenues and expenditures, and proposed solid waste service rate increase options for Council consideration.

Mr. Kulaga discussed the Solid Waste Fund balance from 2005 – 2021; and, reviewed the 2019 Request for Proposals process to solicit bids from solid waste collection providers. It is important to retain a fund balance in order to address needed capital repairs. Mr. Kulaga then reviewed what problems have been solved as a result of selecting a new solid waste provider, including upcoming challenges.

Staff is recommending the following:

1. Discontinue quarterly bulk service.
2. To continue quarterly bulk service, a \$3.00 monthly fee increase would be needed, in addition to rate options.
3. Select a rate increase.

Mr. Kulaga reviewed five rate options for Council consideration and reviewed solid waste utility rate comparisons with the rates of surrounding cities and towns. The rate increase options do not include potential increases in fuel, labor, or landfill tipping fees.

The purpose of this discussion is to introduce rate options. Mr. Kulaga provided a timeline of events should a rate increase ultimately be proposed:

February 11	Introduce rate options
March 11	Clarify information
March 23 – April 21	Solicit public input: website, Facebook, survey, and water bill Water bill insert due to printer March 8
April 22	Council rate decision – with FY2021/2022 proposed budget introduction
April 23	Publish proposed rate / 60 day public notice (A.R.S. 9-449.15)
June 24	Council considers FY2021/2022 budget and solid waste rate fee
July 1	Rate effective

Councilmembers voiced concern about illegal dumping if the quarterly bulk service is eliminated; the importance of not having a negative fund balance by increasing the rate by a minimum of 10%; only a limited amount of residents are able to participate in the quarterly bulk rate pick up due to demand; and, that the Town provides four roll off dumpsters, weekly, at the Town maintenance yard.

Councilmembers asked staff to follow up with providing data on how many solid waste accounts are delinquent and additional information related to the rate increases that the City of Tempe proposing. Mr. Kulaga stated that he will provide additional information at the March 11, 2021, Council meeting.

**4. RIGHT AWAY DISPOSAL (RAD) CONTRACT RENEWAL – AMENDMENT NO. 1**

Jeff Kulaga, Town Manager / Clerk, stated the Town Council initially approved the RAD contract on January 9, 2020. Amendment No. 1 implements an annual rate increase of 1.17% for solid waste services. This amendment complies with the terms of the original contract where annual rate increases shall be in an amount not to exceed the twelve (12) month change in the Consumer Price Index as



Valerie Molina  
Mayor

Ricardo Vital  
Vice Mayor

Mary Bravo  
Councilmember

Gloria Cota  
Councilmember

Elvira Osuna  
Councilmember

Joe Sánchez  
Councilmember

Anita Cota Soto  
Councilmember

Agendas/Minutes:  
[www.guadalupeaz.org](http://www.guadalupeaz.org)

Town Council Chambers  
9241 S. Avenida del Yaqui  
Guadalupe, AZ 85283  
Phone: (480) 730-3080  
Fax: (480)-505-5368

published by the United States Department of Labor, Bureau of Labor Statistics, or 5% greater than the current monthly fee, whichever is less. The impact of the 1.17% rate increase would increase one bin service from \$20.14 to \$20.38, monthly.

**Motion by Vice Mayor Vital to approve agenda item G4; second by Councilmember Osuna. Motion passed unanimously on a voice vote 5-0.**

Councilmembers approved Amendment No. 1, (C2020-01A) to a contract with Right Away Disposal (RAD) for solid waste collection services.

#### 5. REQUEST FOR PROPOSALS – TOWN-OWNED LAND

Jeff Kulaga, Town Manager / Clerk, stated that in 2019 staff issued a Request for Proposals (RFP) to solicit interest in the lease and/or sale and development of Town-owned parcels. At that time, there was little interest in the RFP. At the recent direction of Council, staff has updated the RFP to include the same five town-owned parcels. The locations of the parcels are: 5603 East Calle Iglesia, 5604 East Calle Mexico, northeast and northwest corners of Avenida del Yaqui and Guadalupe Road; 9050 South Avenida del Yaqui, and 9241 South Avenida del Yaqui. Council determine how to proceed with any responses to the RFP. If approved, the RFP will be issued on February 22, 2021, with a response due date of March 31, 2021.

A Councilmember noted that the RFP was originally issued two years ago due to the need to generate revenue for the Town. Guadalupe does not have a property tax. The action being requested is to solicit RFP's from interested parties. In 2019, Mr. Kulaga noted that there was one response to the RFP.

**Motion by Vice Mayor Vital to approve agenda item G5; second by Councilmember Bravo. Motion passed unanimously on a voice vote 5-0.**

Councilmembers authorized staff to issue a Request for Proposals (RFP) to solicit interest in the lease and/or sale and development of Town-owned parcels.

#### 6. CONSULTANT ENGINEERING INCORPORATED (CEI) CONTRACT – AMENDMENT NO. 2

Jeff Kulaga, Town Manager / Clerk, stated that last month Council approved contract Amendment No. 1 with Consultant Engineering Incorporated. Amendment No. 2 is in the amount of \$32,708. Staff recommends approval of contract Amendment No. 2.

**Motion by Vice Mayor Vital to approve agenda item G6; second by Councilmember Bravo. Motion passed unanimously on a voice vote 5-0.**

Councilmembers awarded contract Amendment No. 2 (C2020-02B) for additional services to establish temporary construction easements on private property necessary to complete the \$5 million federally funded Avenida del Yaqui street improvement project to Consultant Engineering Incorporated in the amount of \$32,708. Right-of-way acquisition expenses are not eligible for federal funds. Amendment No. 2 is funded through the approved fiscal year 2020/2021 Town Highway User Revenue Fund (HURF) budget where \$186,806 has been allocated for the Avenida del Yaqui project and related right-of-way expenses.

#### 7. RIGHT OF WAY WARRANTY DEED

Jeff Kulaga, Town Manager / Clerk, stated that Consultant Engineering Incorporated is transitioning 83 square feet of Town-owned land and converting it to right-of-way property to provide for street improvements.

**Motion by Vice Mayor Vital to approve agenda item G7; second by Councilmember Osuna. Motion passed unanimously on a voice vote 5-0.**



Valerie Molina  
Mayor

Ricardo Vital  
Vice Mayor

Mary Bravo  
Councilmember

Gloria Cota  
Councilmember

Elvira Osuna  
Councilmember

Joe Sánchez  
Councilmember

Anita Cota Soto  
Councilmember

Agendas/Minutes:  
[www.guadalupeaz.org](http://www.guadalupeaz.org)

Town Council Chambers  
9241 S. Avenida del Yaqui  
Guadalupe, AZ 85283  
Phone: (480) 730-3080  
Fax: (480)-505-5368

Councilmembers approved a Warranty Deed (C2021-12) to dedicate 83 square feet of Town-owned property located at 8413 South Avenida del Yaqui, where the Fire Station is located, to the Town as public right of way for sidewalk improvements as part of the federally funded \$5 million Avenida del Yaqui street improvement project. Approval of this Warranty Deed transitions Town-owned property to Town right of way.

#### **8. AVENIDA DEL YAQUI – SCHOOL DISTRICT SIDEWALK EASEMENT**

Jeff Kulaga, Town Manager / Clerk, stated that this agenda item is similar to agenda item G7. 205 square feet of land is needed to provide for a sidewalk on the north side of the Magdalena/Avenida del Yaqui intersection. This land is currently owned by the Tempe School District (School District). In the spirit of partnership, the School District has agreed to offer the property to the Town as an easement in the amount of \$10, versus the Town having to pay the fair market value of approximately \$2,500.

**Motion by Vice Mayor Vital to approve agenda item G8; second by Councilmember Osuna. Motion passed unanimously on a voice vote 5-0.**

Councilmembers approved a Sidewalk Easement (C2021-13) from Tempe School District No. 3 (Tempe Elementary) to allow legal access for the right of ingress and egress for the purpose of installations, maintenance and replacement over, under, and across. This easement allows for construction and ongoing maintenance of a sidewalk as part of the Avenida del Yaqui street improvement project. The 205 square foot easement would be located at the immediate northeast corner of Calle Magdalena and Avenida del Yaqui.

#### **9. HIGHLINE CANAL PATH LIGHTING DESIGN PROJECT**

Jeff Kulaga, Town Manager / Clerk, stated that the lighting along the Highline Canal pathway has been a target of vandalism and theft. Currently, there is no lighting along the pathway. In 2016, the multi-use path beautification project lighting was installed utilizing Salt River Project (SRP) aesthetic funds. Solar panels provide the lighting. Each unit requires three batteries at a cost of \$250 each, all of which have been stolen. Dibble Engineering would like to provide plans for electrical lighting units which will increase security and be less likely to be a target of theft and vandalism. The \$77,981 will cover the cost of the redesign and preparation of final construction plans for the system. The estimated cost of construction is approximately \$350,000. Once the final construction plans have been completed, staff will be positioned to apply for gaming grant funds and Maricopa County Community Block Grant funding. Staff recommends approval of this contract. SRP does not typically allocate aesthetic funds for repair and replacement projects.

In response to a question, Mr. Kulaga stated that he will provide Council with additional information on how much it has cost the Town for battery replacements over the past two years. He noted that the existing lighting system was selected by a prior Council.

Councilmembers expressed frustration at having to spend additional money on this project; the proposed contract amount will tie into the lighting on the main street; and, that the cost of lighting the pathway is paid for by the Town. It was unclear what the difference in the price for electrical versus solar lighting will be. If the equipment is replaced, replacement costs for batteries and copper wiring will no longer exist.

A Councilmember expressed a desire to make the lights taller. Mr. Kulaga noted that staff will work with the Town engineer to make the lights and fixtures as free of vandalism and theft as possible. Vince Gibbons, Dibble Engineering representative, stated that the lighting poles will be higher to improve light distribution and to mitigate vandalism and theft.

**Motion by Councilmember Bravo to approve agenda item G9; second by Vice Mayor Vital. Motion passed unanimously on a voice vote 5-0.**



Valerie Molina  
Mayor

Ricardo Vital  
Vice Mayor

Mary Bravo  
Councilmember

Gloria Cota  
Councilmember

Elvira Osuna  
Councilmember

Joe Sánchez  
Councilmember

Anita Cota Soto  
Councilmember

Agendas/Minutes:  
[www.guadalupeaz.org](http://www.guadalupeaz.org)

Town Council Chambers  
9241 S. Avenida del Yaqui  
Guadalupe, AZ 85283  
Phone: (480) 730-3080  
Fax: (480)-505-5368

Councilmembers awarded a contract (C2021-14) to the Town Engineer, Dibble Engineering for design, bid process, construction administration, and inspection services for the conversion of Highline Canal pathway lighting from a battery powered solar lighting system to an electric powered system in the amount of \$77,981. The purpose of this project is to resolve the ongoing theft, vandalism, and maintenance problems to provide a safe, efficient, improved, and cost effective pedestrian path lighting system. Funding for this contract is through the approved fiscal year 2020/2021 Town Highway User Revenue Fund (HURF) and General Fund Capital Outlay budgets.

#### 10. DIBBLE ENGINEERING CONTRACT

Jeff Kulaga, Town Manager / Clerk, stated that Dibble Engineering was initially awarded the Town Engineer contract by Council on January 28, 2016, with a term expiring February 1, 2021. Mr. Kulaga outlined the various projects where Dibble Engineering has provided engineering services for the Town and noted that Dibble Engineering also serves as the Town's Building Inspector. Award of this contract complies with Town Code requirements. Dibble Engineering is also offering their 2019 hourly rates, rather than their 2021 rates.

**Motion by Vice Mayor Vital to approve agenda item G10; second by Councilmember Sánchez. Motion passed unanimously on a voice vote 5-0.**

Councilmembers awarded a five-year contract (C2021-15) for Town Engineer services to Dibble Engineering to provide ongoing engineering related services to the Town. The contract term is February 1, 2021, to February 1, 2026. This contract is funded annually through the Highway User Revenue Fund (HURF).

#### 11. ARIZONA RESTAURANT SUPPLY INCORPORATED CONTRACT

Jeff Kulaga, Town Manager / Clerk, stated that the Town received grant funding from the Area Agency on Aging that covers the cost of the purchase and installation of a walk-in refrigerator for the Senior Center. Staff solicited three bids and is recommending that the award of bid go to Arizona Restaurant Supply because Arizona Restaurant Supply offered the best warranty and will ensure that all of the plumbing and electrical needs for the walk-in refrigerator are met.

In response to questions, Mr. Kulaga stated that the existing walk-in refrigerator is approximately the same size as the proposed walk-in refrigerator; and, because the Community Action Program office area would require additional construction to add a walk-in refrigerator to the space, it is more cost effective to address the current need to replace the Senior Center walk-in refrigerator.

**Motion by Vice Mayor Vital to approve agenda item G11; second by Councilmember Sánchez. Motion passed unanimously on a voice vote 5-0.**

Councilmembers awarded a contract (C2021-16) for the purchase, installation, and warranty of a walk-in refrigerator for the Senior Center, to Arizona Restaurant Supply, Inc., in the amount of \$39,557.96. The existing walk-in refrigerator has exceeded its serviceable life expectancy and requires on-going repair. Funding for replacing the walk-in refrigerator is through a grant from the Area Agency on Aging. Staff received three bids and recommends awarding the contract to Arizona Restaurant Supply, Inc., because Arizona Restaurant Supply, Inc., provided the lowest bid for the product, installation, and warranty.

#### 12. TOWN FINANCIAL SESSIONS CALENDAR

Jeff Kulaga, Town Manager / Clerk, presented the schedule of upcoming Council meetings where fiscal review, budget review and adoption, and solid waste rate review agenda items will be scheduled for upcoming presentations to Council as follows:



February 25, 2021	FY 2020/21 Mid-year budget status report
March 11, 2021	Solid Waste Rate Information
March 25, 2021	FY 2021/22 Gaming grant proposals
April 22, 2021	Five year forecast; Introduce FY 2021/22 budget & propose Solid Waste Rates
May 13, 2021	Review Proposed FY 2021/22 Tentative budget
May 27, 2021	Adopt FY 2021/22 Tentative budget
June 24, 2021	Adopt FY 2021/22 Final budget

Valerie Molina  
Mayor

Ricardo Vital  
Vice Mayor

Mary Bravo  
Councilmember

Gloria Cota  
Councilmember

Elvira Osuna  
Councilmember

Joe Sánchez  
Councilmember

Anita Cota Soto  
Councilmember

Agendas/Minutes:  
[www.guadalupeaz.org](http://www.guadalupeaz.org)

Town Council Chambers  
9241 S. Avenida del Yaqui  
Guadalupe, AZ 85283  
Phone: (480) 730-3080  
Fax: (480)-505-5368

**13. CLAIMS**

Approval of the check register for January 2021, totaling \$488,088.96.

**Motion by Vice Mayor Vital to approve agenda item G13; second by Councilmember Bravo. Motion passed unanimously on a voice vote 5-0.**

Councilmembers approved the check register for January 2021, totaling \$488,088.96.

**H. TOWN MANAGERS' COMMENTS**

Jeff Kulaga, Town Manager / Clerk

- Homelessness in the Town of Guadalupe has spiked recently. Staff has partnered with The Crisis Network and the Maricopa County Sheriff's Office to assist those in need.

**I. COUNCILMEMBERS' COMMENTS**

Vice Mayor Vital

- Urged everyone to take precautions during Cuaresma and to practice social distancing.

Councilmember Osuna

- Thanked community members for wearing masks, staying safe, and caring for elders.

Councilmember Bravo

- Thanked community members for wearing masks and social distancing.

Councilmember Sánchez

- Thanked his colleagues for their work.

Mayor Molina

- February 25, 2021 – Live FaceBook meeting with Maricopa County Sheriff, Paul Penzone. Community members may submit questions in advance. Topics of discussion will include fighting drug activity in the community and ensuring that the community is safe an protected. Information is available on the Town's FaceBook webpage and on the Town marquee.
- The Town is not issuing party permits. There should be no bands, amplified music, bands, or large gatherings during Cuaresma.

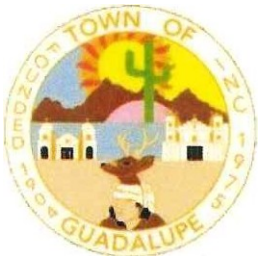

J. ADJOURNMENT

**Motion by Vice Mayor Vital to adjourn the Regular Council Meeting; second by Councilmember Bravo. Motion passed unanimously on a roll call vote 5-0.**

The meeting was adjourned at 7:59 p.m.

\_\_\_\_\_  
Valerie Molina, Mayor

Valerie Molina  
Mayor

ATTEST:

Ricardo Vital  
Vice Mayor

\_\_\_\_\_  
Jeff Kulaga, Town Manager / Town Clerk

Mary Bravo  
Councilmember

CERTIFICATION

I hereby certify that the foregoing minutes are a true and correct copy of the minutes of the February 11, 2021, Town of Guadalupe, Town Council Regular Meeting. I further certify the meeting was duly called and held, and that a quorum was present.

Gloria Cota  
Councilmember

\_\_\_\_\_  
Jeff Kulaga, Town Manager / Town Clerk

Elvira Osuna  
Councilmember

Joe Sánchez  
Councilmember

Anita Cota Soto  
Councilmember

Agendas/Minutes:  
[www.guadalupeaz.org](http://www.guadalupeaz.org)

Town Council Chambers  
9241 S. Avenida del Yaqui  
Guadalupe, AZ 85283  
Phone: (480) 730-3080  
Fax: (480)-505-5368



# PROCLAMATION

## A PROCLAMATION BY VALERIE MOLINA AS MAYOR OF THE TOWN OF GUADALUPE DECLARING AN EMERGENCY

**WHEREAS**, the property located at 8427 South Calle Batoua, Guadalupe, Arizona (hereafter “the Property”) is within the jurisdictional limits of the Town of Guadalupe, an Arizona municipal corporation; and

**WHEREAS**, the owner of record according to the records of the Maricopa County Recorder and the Maricopa County Assessor is Tomas Villegas who is deceased, and

**WHEREAS**, the Town, despite diligent efforts, has been unable to locate heirs or anyone who claims ownership or control of the property; and

**WHEREAS**, the Property is a haven for illegal drug activity and other criminal acts and is covered with garbage/refuse, used hypodermic needles, human waste, broken glass, and other trash and debris; and

**WHEREAS**, the unwholesome and unsanitary conditions described at the Property are a hazard to the health, safety, and welfare of the community and therefore an emergency exists requiring immediate emergency action; and

**WHEREAS**, the Town Code of the Town of Guadalupe § 30-023, and the Arizona Revised Statutes § 26-311 provide authority to the mayor to issue a proclamation declaring that the condition of the Property described herein is a local emergency requiring immediate action to protect the health and welfare of the community.

**NOW THEREFORE**, pursuant to the authority granted to me by the Town Code of Guadalupe, and the Arizona Revised Statutes, I hereby declare:

1. That an emergency exists at the Property located at 8427 South Calle Batoua which constitutes an extreme health hazard requiring immediate and decisive emergency action to remedy.
2. The Town Manager/Clerk is hereby directed to take any legal means necessary to clean and clear the Property and remedy the emergency situation thereon.

DATED FEBRUARY 25, 2021.

\_\_\_\_\_  
Valerie Molina, Mayor  
Town of Guadalupe

ATTEST:

APPROVED AS TO FORM:

\_\_\_\_\_  
Jeff Kulaga  
Town Manager/Clerk

\_\_\_\_\_  
David E. Ledyard, Town Attorney  
Faith, Ledyard & Faith, PLC

**ORDINANCE NO. O2021.01**

AN ORDINANCE OF THE TOWN COUNCIL OF THE TOWN OF GUADALUPE, ARIZONA, AMENDING THE TOWN OF GUADALUPE CODE OF ORDINANCES BY ADDING A NEW SUBCHAPTER TITLED RECREATIONAL MARIJUANA – § 154.086 THROUGH § 154.090 – TO CHAPTER 154 ZONING. SAID ORDINANCE REGULATES RECREATIONAL MARIJUANA, ESTABLISHING A PURPOSE SETTING FORTH DEFINITIONS; PROHIBITING MARIJUANA ON PUBLIC PROPERTY; PROHIBITING RECREATIONAL MARIJUANA ESTABLISHMENTS AND MARIJUANA TESTING FACILITIES; PROVIDING FOR THE REPEAL OF CONFLICTING ORDINANCES; SETTING FORTH VIOLATIONS; PROVIDING FOR ENFORCEMENT AND PENALTIES; PROVIDING FOR EXEMPTIONS; PROVIDING FOR SEVERABILITY; AND SETTING AN EFFECTIVE DATE.

WHEREAS, marijuana contains tetrahydrocannabinol (“THC”), which remains on Schedule I of the Controlled Substances Act pursuant to 21 U.S.C. § 811 et al. and any possession and use is a violation of federal law pursuant to 21 U.S.C. § 841 et. al.;

WHEREAS, the Arizona Medical Marijuana Act, Arizona Revised Statutes, Sections § 36-2801 et al., and Title 9, Chapter 17 of the Arizona Administrative Code allow the establishment and operation of nonprofit medical marijuana dispensaries in the Town according to a prescribed statutory and regulatory process;

WHEREAS, the statewide ballot measure known as the “Smart and Safe Arizona Act” was certified as Proposition 207 and was approved by the voters at the November 3, 2020 general election ballot and contains provisions authorizing the possession, consumption, purchase, processing, manufacturing or transporting of marijuana by an individual who is at least twenty-one (21) years of age; allowing a nonprofit medical marijuana dispensary or other non-dispensary applicant to apply to the Department of Health Services to become a licensed marijuana establishment authorized to engage in the retail sale, cultivation and manufacturing of marijuana; and allowing the Department, or another entity designated by the Department, to become a marijuana testing facility to test the potency of marijuana and detect any harmful contaminants;



WHEREAS, Proposition 207 authorizes marijuana establishments and testing facilities to use chemical extraction or chemical synthesis, including butane and other flammable gases, to extract marijuana concentrate, which poses a threat to the health, safety and welfare of the Town and increases the responsibility of the police, fire, and other departments of the Town to respond to violations of state and local laws;

WHEREAS, the Town seeks to protect public health, safety, and welfare by prohibiting marijuana establishments and marijuana testing facilities in the Town.

NOW THEREFORE, BE IT ORDAINED by the Town Council of the Town of Guadalupe, Arizona, as follows:

Section I. In General.

The Code of Ordinances of the Town of Guadalupe, Arizona, Chapter 154 Zoning, is hereby amended by adding a new Subchapter entitled Recreational Marijuana §154.086 through §154.090:

Subsection 154.086 Purpose

The purpose of this amendment is to protect the health, safety, and welfare of the community. Except as allowed by law for personal use, the Town prohibits the retail sale, cultivation, storage, processing, testing, and manufacturing of marijuana products in the Town, except as set forth hereafter.

Section 154.087 Definitions

The words listed hereafter are to be construed as defined in this Section unless it is clear for the context another meaning is intended.

- A. Chemical Extraction means the process of removing a particular component of a mixture from others present, including removing resinous tetrahydrocannabinol from marijuana.
- B. Chemical Synthesis means production of a new particular molecule by adding to, subtracting from, or changing the structure of a precursor molecule.
- C. Consume, Consuming, and Consumption mean the act of ingesting, inhaling or otherwise introducing marijuana into the human body.
- D. Consumer means a person who is at least 21 years old and who purchases marijuana or marijuana products.
- E. Cultivate and Cultivation mean to propagate, breed, grow, prepare, and package marijuana.
- F. Department means the State of Arizona Department of Health Services or its successor agency.
- G. Dual Licensee means an entity that holds both a nonprofit medical marijuana dispensary registration and a marijuana establishment license.
- H. Extraction means the process of extracting or separating resin from marijuana to produce or process any form of marijuana concentrates using water, lipids, gases, solvents, or other chemicals or chemical processes.

- I. Manufacture and Manufacturing mean to compound, blend, extract, infuse or otherwise make or prepare a marijuana product.
- J. Marijuana
1. Means all of the parts of the plant genus cannabis, whether growing or not, as well as the seeds from the plant, the resin extracted from any part of the plant, and every compound, manufacture, salt, derivative, mixture or preparation of the plant or its seeds or resin.
  2. Includes cannabis as defined in A.R.S. § 13-3401.
  3. Does not include industrial hemp, the fiber produced from the stalks of the plant of the genus cannabis, oil or cake made from the seeds of the plant, sterilized seeds of the plant that are incapable of germination, or the weight of any other ingredient combined with marijuana to prepare topical or oral administrations, food, drink or other products.
- K. Marijuana Concentrate
1. Means resin extracted from any part of a plant of the genus cannabis and every compound, manufacture, salt compound, derivative, mixture, or preparation of that resin or tetrahydrocannabinol.
  2. Does not include industrial hemp or the weight of any other ingredient combined with cannabis to prepare topical or oral administrations, food, drink or other products.
- L. Marijuana Establishment
- Means an entity licensed by the Department to operate all of the following:
1. A single retail location at which the licensee may sell marijuana and marijuana products to consumers, cultivate marijuana and manufacture marijuana products.
  2. A single off-site cultivation location at which the licensee may cultivate marijuana, process marijuana and manufacture marijuana products, but from which marijuana and marijuana products may not be sold.
  3. A single off-site location at which the licensee may manufacture marijuana products and package and store marijuana, and marijuana may not be sold to consumers.
- M. Marijuana Products means marijuana concentrate and products that are composed of marijuana and other ingredients and that are intended for use or consumption, including edible products, ointments, and tinctures.
- N. Marijuana Testing Facility means the Department or another entity that is licensed by the Department to analyze the potency of marijuana and test marijuana for harmful contaminants.
- O. Nonprofit Medical Marijuana Dispensary as defined in A.R.S. § 36-2801(12).

- P. Open Space  
To the fullest extent allowable by law means a public park, public sidewalk, public walkway, public trail, preserve, public pedestrian thoroughfare, public property, public conveyance, such as a taxi, bus or school bus, or other area that is open to the public.
- Q. Person means an individual, partnership, corporation, association, or any other entity of whatever kind or nature.
- R. Process and Processing means to harvest, dry, cure, trim or separate parts of the marijuana plant.
- S. Public Place has the same meaning prescribed in the Smoke-Free Arizona Act, A.R.S. § 36-601.01.
- T. "Smoke" means to inhale, exhale, burn, carry or possess any lighted marijuana or lighted marijuana products whether natural or synthetic. To the extent permitted by law, "smoke" shall also mean the use of an electronic cigarette.

**Subsection 154.087 Marijuana Prohibited on Public Property.**

- A. The use, sale, cultivation, manufacture, production, storage, or distribution of marijuana or marijuana products is prohibited on property that is occupied, owned, controlled or operated by the Town.
- B. It is unlawful for an individual to smoke marijuana or consume marijuana products on property that is occupied, owned, controlled or operated by the Town. This subsection shall not apply to lawful activities of law enforcement agencies.
- C. It is unlawful for an individual to smoke marijuana or consume marijuana products in any open space in the Town.

**Subsection 154.088 Marijuana Establishment Prohibited; Exemptions**

- A. To the fullest extent allowable by law, the operation of a marijuana establishment is prohibited in the Town, except where authorized for a dual licensee who:
1. Operates both a licensed nonprofit medical marijuana dispensary and said medical marijuana dispensary was licensed to operate within the Town limits of the Town of Guadalupe prior to the passage of Proposition 207 known as the "Smart and Safe Arizona Act," pursuant to Guadalupe Town Ordinance 2011-02 as modified by Guadalupe Town Ordinance 2016-01 and the right to continue such operation was confirmed by Guadalupe Town Ordinance 2017-02 and further has since obtained a license from the Department to operate a marijuana establishment from the Department at the same location as the medical marijuana dispensary; and
  2. Has not forfeited or terminated the nonprofit medical marijuana dispensary registration from the Department.

- B. An allowed marijuana establishment shall:
  - 1. Be open to the public for business no earlier than 8:00am and no later than 10:00pm; and
  - 2. In addition to any permits or licenses issued by the State of Arizona and any of its departments or subdivisions, such marijuana establishment shall obtain a Town of Guadalupe Business license and a privilege tax license.

**Section 154.089 Marijuana Testing Facility Prohibited**

To the fullest extent allowable by law, the operation of a marijuana testing facility is prohibited in the Town.

**Section 154.090 Violations; Enforcement; Penalties.**

- A. It is unlawful and a violation for a person to sell, cultivate, process, manufacture, store, or transport marijuana or marijuana products if the person fails to meet all of the requirements in this code or state law, including the Department's rules.
- B. Each day any violation of any provision of this Section of the Code shall continue shall constitute a separate, public offense.
- C. Except as otherwise provided in A.R.S. § 36-2853, any violation of this Subchapter § 154.086 through § 154.090 shall be a violation of Section 10.99 of this code.
- D. Violations of this Subchapter are in addition to any other violation enumerated within the Town ordinances or the Town Code and in no way limits the penalties, actions, or abatement procedures which may be taken by the Town for any violation of this Subchapter, which is also a violation of any other ordinance or Code provision of the Town, or Federal or State law. Conviction and punishment or judgment and civil sanction against any other person shall not relieve such person from the responsibility of correcting prohibited conditions, or removing prohibited structures or improvements, and shall not prevent the enforced correction or removal thereof.
- E. The remedies provided herein shall be cumulative and in addition to any other federal, state or local remedy which may be available. Nothing contained herein shall be construed to preclude prosecution under any other applicable statute, ordinance, rule, order or regulation.

**Section II. Providing for Repeal of Conflicting Ordinances.**

All ordinances and parts of ordinances in conflict with the provisions of this Ordinance or any part of the Code adopted herein by reference, are hereby repealed.

**Section III. Recitals.**

The recitals above are fully incorporated in this Ordinance by reference.

Section IV. Effective Date.

This Ordinance shall be effective 30 days after its passage by the Town Council of Guadalupe.

Section V. Zoning Considerations.

In accordance with the Arizona Constitution, the Town Council of Guadalupe has considered the property rights and liberties of the residents and property owners of the Town of Guadalupe.

Section VI. Preservation of Rights and Duties.

This Ordinance does not affect the rights and duties that matured, penalties incurred, or proceedings that were begun before the effective date of this Ordinance.

Section VII. Providing for Severability.

If any part of this Ordinance or any part of the Code adopted herein by reference is held to be invalid or unconstitutional by any court of competent jurisdiction, such decision shall not affect the validity of the remaining provisions thereof.

PASSED and ADOPTED by the Common Council of the Town of Guadalupe, Arizona, this \_\_\_\_ day of \_\_\_\_\_, 2021, by a vote of \_\_\_\_ AYES and \_\_\_\_ NAYES.

APPROVED this \_\_\_\_ day of \_\_\_\_\_, 2021.

\_\_\_\_\_  
Valerie Molina, Mayor

Attest:

Approved as to Form:

\_\_\_\_\_  
Jeff Kulaga  
Town Manager / Clerk

\_\_\_\_\_  
FAITH, LEDYARD & FAITH, PLC  
Town Attorney  
By David E. Ledyard

I, Jeff Kulaga, Town Manager / Clerk, do hereby certify that a true and correct copy of Ordinance No. O2021.01 was adopted by the Town Council of Guadalupe on the \_\_\_\_ day of \_\_\_\_\_, 2021, and thereof was posted in four places on the \_\_\_\_ day of \_\_\_\_\_, 2021.

\_\_\_\_\_  
Jeff Kulaga, Town Manager / Clerk

# THE RECORD REPORTER

~SINCE 1914~

Mailing Address : 2025 N THIRD ST #155, PHOENIX, AZ 85004-1425  
Telephone (602) 417-9900 / Fax (602) 417-9910  
Visit us @ www.RecordReporter.com

KAY SAVARD  
TOWN OF GUADALUPE  
9241 S AVENIDA DEL YAQUI  
GUADALUPE, AZ 85283

RR# 3438968

## COPY OF NOTICE

(Not an Affidavit of Publication. Do not file.)

Reference #

Notice Type: MCHRG NOTICE OF HEARING

Ad Description  
RECREATIONAL MARIJUANA (ORDINANCE NO. O2021.01)

To the right is a copy of the notice you sent to us for publication in THE RECORD REPORTER. Please read this notice carefully and fax or e-mail (record\_reporter@dailyjournal.com) any corrections. The Affidavit will be filed, if required, and mailed to you after the last date below. Publication date(s) for this notice is (are):

02/08/2021

Notice of Public Hearing The Guadalupe Town Council will hold a public hearing on Thursday, February 25, 2021, at 6:00 p.m., Guadalupe Town Hall, 9241 S. Avenida del Yaqui, Museum Room, Guadalupe, AZ 85283, to receive public comment on the following: RECREATIONAL MARIJUANA (ORDINANCE NO. O2021.01): Ordinance to adopt regulations for use of recreational marijuana by adding a new subchapter titled Recreational Marijuana – § 154.086 through § 154.090 – to Chapter 154 Zoning. The ordinance regulates recreational marijuana by establishing a purpose; setting forth definitions; prohibiting marijuana on public property; prohibiting recreational marijuana establishments and marijuana testing facilities; providing for the repeal of conflicting ordinances; setting forth violations; providing for enforcement and penalties; providing for exemptions; providing for severability; and setting an effective date. Publish: Monday, February 8, 2021 2/8/21

RR-3438968#

The charge(s) for this order is as follows. An invoice will be sent after the last date of publication. If you prepaid this order in full, you will not receive an invoice.

Publication	\$2.40
Arizona Sales Tax	\$0.01
Total	\$2.41

Your Legal Publishing



\* A 0 0 0 0 0 5 6 3 5 9 1 5 \*



TOWN OF GUADALUPE  
FY 2020-2021 Mid-year Report  
February 25, 2021

**TO:** Mayor and Town Council

**THRU:** Jeff Kulaga, Town Manager / Clerk

**FROM:** Bob Thaxton, Finance Director

**DATE:** February 18, 2021

Presented for Town Council review is a comprehensive Fiscal year 2020-21 (FY20) mid-year (July 2020–December 2020) budget report. This report provides an overview of the Town’s cost centers:

1. General Fund,
2. Highway User Revenue Fund (HURF),
3. Local Transportation Assistance Fund (LTAF),
4. Senior Center,
5. Community Action Program,
6. MPC Bond
7. CARES Act – Pascua Yaqui Tribe,
8. CARES Act – State of Arizona,
9. Mercado,
10. Wastewater/Sewer and,
11. Solid Waste.

This report follows the tables and charts presented in the attached PowerPoint presentation: FY 2020/21 Mid-Year Budget Report, prepared for Town Council February 25, 2021. This report illustrates the Town financial status through the mid-year of FY21.

### GENERAL FUND SUMMARY

Overall, based on revenue and expenditure analysis of FY 21, Guadalupe’s financial performance is tracking favorable to the annual budget projections for revenues and expenditures.

**Table A: FY21 Revenues** through December (first six months of the fiscal year) should be at 50% of the adopted FY20/21 budget of \$5,346,719. With total revenues at the end of December 2020 at 62% of the adopted budget, actual revenues are exceeding adopted budget amounts. For example, Local Sales Tax is at 78% or \$421,083 more than expected for a six month period and Transient Occupancy Tax of \$115,709 has already exceeded the adopted amount of \$101,226. As a result, there is no use of fund balance which was projected to be at 50% or \$159,241 through December.

**Table B: FY20 Expenditures** total \$2,089,785 or 39% of the adopted \$5,346,719 budget through the first six months of FY21. Expenditures are lower than expected by 11% primarily as a result of CARES Act funds received. Notably savings have occurred in Police and Fire services, as well as cemetery and administration cost centers. CARES Act Relief funds have been exhausted and expenses are projected to increase by 6% for the remainder of the year. As a result, it is estimated that \$400,000 savings in General Fund expenditures will occur in FY21. In turn, use of General Fund balance dollars will not be needed.

**Table C: General Fund Expenditures** as adopted, by Cost Center summarizes the adopted FY 21 expenditures of \$5,346,719 for the Town. MCSO, Fire, Transfers to Other Funds and Administration total 80% of the entire General Fund budget. All other funds are individually no more than 3% of the entire Town General Fund budget expenses. This demonstrates that the Town of Guadalupe presently only provides minimal levels of public service.

**Chart A: Cost Center % of Total FY21 Budget** corresponds to Table C by illustrating each cost center's expenses compared to the total General Fund budget.

**Table D: Public Safety and Other Cost Centers Adopted FY19/21 Budget** points out that public safety is nearly double the amount of all other cost centers combined. Public safety expenditures total \$3,394,336 while all other cost centers total \$1,952,383.

**Chart B: Public Safety Portion of the Adopted Budget FY21** illustrates the need for additional continuing revenue streams to keep up with the increasing costs of public safety services provided to the community. Public safety is 63% or \$3,394,336 of the total General Fund expenses.

**Chart C: General Fund Monthly Revenues and Expenditures Comparison** illustrates the projected FY21 revenues and expenses based on this year's performance and the past five years. This analysis suggests that although revenues increased and expenses decreased during the first six months of FY21, projections for the remaining six months indicate that revenues and expenditures return to the historic trends where monthly revenues and expenses are nearly equal.

**Table E: General Fund Takeaways – Mid Year FY20/21** As noted, revenues are exceeding expenses through the first six months of the fiscal year by \$1,226,313. As a result, with revenues and expenditures being nearly equal for the remainder of the FY21, it is projected that revenues will exceed expenditures by \$1,363,365 for FY21. Should this result, this would mark the fourth consecutive year revenues exceed expenditures in the Town's General Fund.

**Chart D: Monthly Revenues and Expenses** illustrates that during this year, including the past 3 years, revenues have exceeded expenditures resulting in a General Fund balance increase of \$2,945,370 from \$891,034 to \$3,836,404. This allows the Town to maintain 25% of annual expenditures in the General Fund balance.

**Table F: General Fund: Yes, But.....** Based on six months performance suggests an end of the year General Fund balance to be an estimated \$3.8M. Should this estimate hold, the impact to the fund balance would allow for infrastructure repairs, debt reduction, employee compensation, enhancing levels of service, and maintaining a Government Finance Officers Association recommended fund reserve of 25% or 3 months of annual expenditures.



## SPECIAL FUND SUMMARIES

**Table G: Highway User Revenue Fund** are generated from gasoline taxes and are only eligible to be used for transportation and street-related purposes. The Town maintains the HURF revenues and expenditures in a separate fund to ensure compliance with this requirement.

Table G shows HURF revenue totals \$219,023 for FY21 mid-year. Overall, HURF revenue totals 47% of budget projections. This is slightly under budget of the projected 50% or \$12,000. This shortage is likely due to less miles traveled and use of fuel during the pandemic. Primarily due to the one time allocation of \$197,800 transportation funds from the State Legislature through the FY20 State budget, the HURF fund is not dependent on General Fund transfers this year. However, it is expected HURF will require transfers from the General Fund in future years. The Avenida del Yaqui Project will use all the one-time State FY20 monies.

**Table H: Local Transportation Assistance Fund (LTAF):** provides funds for Senior Center transportation operations. Annually, revenues are not received until April and are expected to be \$16,740. As a result, this causes an early FY dependence on the Transfer in amount of \$19,360 from the General Fund. For FY21, LTAF relies on \$16,740 of LTAF funds and \$21,443 of General Fund transfers. This is a comparatively small fund that provides resources for valuable Senior services.

**Table I: Senior Center:** The Senior Center budget includes four cost centers:

1. Congregate Meals made and served at the Center.
2. Home delivered meals made at the Center and delivered to qualifying individuals.
3. Multi-Purpose Services provide activities and craft education to seniors.
4. Transportation transports seniors to and from the Center, medical appointments, pharmacies, and local visitations to other facilities.

Table I indicates that YTD revenues are \$107,241 with a General Fund transfer of \$33,687 or 35% of adopted budget amounts. Area Agency on Aging revenues are performing as projected at 51% and the transfers from the General Fund are performing at 44% of the adopted budget. This is a result of expenditures being under budget at 35% or \$33,687. Fiscally, the Senior Center is performing better than expected this fiscal year.

**Table J: Community Action Program (CAP):** CAP offers social services including senior food boxes, emergency food supplies, utility and rental payment assistance and holiday meal assistance. Table J indicates YTD FY21 expenditures are \$49,333 and actual revenues are \$28,485, requiring a General Fund transfer of \$21,448 through the first six months of FY21. The FY 21 adopted budgeted transfer from the General Fund to CAP is \$68,554. CAP expenses may result in lesser transfer of approximately \$45,000, resulting in a General Fund savings of approximately \$23,000.

**Table K: Pascua Yaqui Tribe CARES Act Fund:** The Pascua Yaqui Tribe CARES Act is a new fund directly related to relief and emergency needs due to the COVID-19 pandemic. The Tribe and Town of Guadalupe entered into an agreement allowing the Town to act as a sub-recipient of the \$2,002,000 of CARES Act funds to assist Guadalupe residents with a multitude of COVID19 relief programs. All programs and related expenses must comply with federal guidelines. The funding of \$2,002,000 was received by Guadalupe in the first quarter of FY21 and expenses from March 1st, 2020 through December 31st, 2020 totaled \$2,048,481. Any amount greater than the \$2,002,000 will be transferred to the General Fund.

**Table L: State of Arizona CARES Act funds:** The AZ CARES Act funds were provided to the State from the federal government to be used for pandemic relief. The Town of Guadalupe is a sub-recipient to the State for \$761,282. Like the PYT funds, all expenditures must comply with federal guidelines. From March 1, 2020 through December 31, 2020, the Town utilized the \$761,282 to fund eligible first responder public safety expenses.

**Table M: MPC Bond:** The bond fund is consistent and annually requires a transfer from the General Fund of \$287,350. There are two more annual bond payments remaining. This bond expires in FY 2023.

**Table N: Transfer to Other Funds:** Transfers are under budget with the exception of the State Cares Act fund that was not budgeted. As a result of the \$761,282 in Sate CARES Act funds requiring a transfer, the Transfer fund is unexpectedly over budget. At the time the FY 20/21 budget was adopted, it was not known that the federal CARES Act funds required separate reporting.

### **ENTERPRISE FUND SUMMARIES**

**Table O: Mercado Fund:** The Mercado revenues total \$78,907 which is 44% of annual adopted budget revenues, slightly less than forecasted amounts. FY21 forecast estimates expenditures will exceed revenues by \$10,769 leaving a fund balance of only \$21,525 to begin the new fiscal year 21/22. The Mercado fund balance is approaching \$0.00 and the Mercado is in need of numerous repairs, including an entire new roof estimated at \$500,000. Should the Mercado fund reach a zero balance, it then becomes a policy question as to whether or not the General Fund should subsidize the Mercado fund.

**Table P: Wastewater / Sewer Fund:** FY21 revenues and expenditures are budgeted at \$666,685 with \$517,828 received in a County CDBG grants to fund sewer line repairs and replacement as identified in the 2018 Waste Water System Assessment Study. As a result, expenditures will exceed revenues by \$32,288 resulting in use of Wastewater earnings to balance the FY20/21 budget.

**Table Q: Solid Waste:** For the first six month of FY20/21 revenues are exceeding expenditures by \$12,398. This is the first year with the Town's new solid waste service provider and adjustments are being made. It is projected that solid waste fund revenues will exceed expenditures by approximately \$21,000 through FY 20/21. In addition, the Town is entering into a new contract year with our current vendor and it is expected that the contract price will increase by 1.17%. In order to continue services at the current level the Mayor and Council may have to consider a residential rate increase.

**In summary:** The Town of Guadalupe manages 11 funds to provide public services to the Town. The majority of these funds are performing as expected or slightly better in the case of the General Fund. However, without recurring sustainable revenue streams difficult fiscal challenges are anticipated.



# **FY 2020/21 Mid Year Budget Report**

*February 25, 2021*



## General Fund Mid-Year YTD Revenue Compared to Adopted FY 20/21 Budget

Revenues	Actual YTD	Adopted FY21	% of YTD
Local Sales Tax	1,170,491	1,498,817	78%
Franchise Tax	12,520	26,697	47%
Transient Occupancy Tax	115,709	101,226	114%
Alcoholic Beverage License	4,000	6,728	59%
Restaurant Bar Tax	102,732	159,663	64%
Business License	5,730	10,957	52%
Building Permits & Fees	11,762	39,527	30%
Billboard Revenues	31,422	63,081	50%
AZ-Cares Fund Allowance	761,282	761,282	100%
Urban Revenue Sharing	473,831	947,663	50%
State Sales Tax	379,328	601,110	63%
Other Rev. from Gov. Agencies	10,270	304,538	3%
Wild Land Reimbursements	0	50,000	0%
Vehicle in Lieu Tax	158,119	304,005	52%
Fines & Forfeitures	0	0	0%
JCEF & Fill the Gap Revenues	23,000	0	100%
Investment Earnings	745	14,554	5%
Rents & Concessions	42,450	86,477	50%
Town Permitting Fees	6,705	21,714	31%
Grant Revenue	6,000	0	100%
Event Revenue	0	30,199	0%
Fund Balance Carryforward -GF	0	318,481	0%
<b>TOTAL REVENUES</b>	<b>3,316,096</b>	<b>5,346,719</b>	<b>62%</b>



**Table B (\$)**  
**General Fund Mid-Year YTD Expenditures**  
**Compared to Adopted FY 20/21 Budget**

Cost Center	Actual YTD	Adopted Budget FY21	Remaining Budget	% of YTD
Mayor & Council	32,642	65,576	32,934	50%
<b>Municipal Court</b>	<b>64,852</b>	<b>49,280</b>	<b>-15,572</b>	<b>132%</b>
Town Manager	38,573	146,530	107,957	26%
Administration	83,517	355,590	272,073	23%
<b>Transfers to Other Funds</b>	<b>979,458</b>	<b>519,422</b>	<b>-460,036</b>	<b>189%</b>
Finance	64,098	140,001	75,903	46%
Attorney	26,232	65,500	39,268	40%
Town Clerk	13,036	41,275	28,239	32%
Community Development	54,786	128,617	73,831	43%
<b>Information Technology</b>	<b>37,806</b>	<b>59,689</b>	<b>21,883</b>	<b>63%</b>
Building Official	0	0	0	0%
Building Maintenance	73,921	122,211	48,290	60%
Police Services	258,350	2,056,429	1,798,079	13%
Fire	277,336	1,337,907	1,060,571	21%
Cemetery	4,787	22,124	17,337	22%
Parks	76,001	182,431	106,430	42%
Library	4,390	10,818	6,428	41%
Capital Outlay	0	43,319	43,319	0%
<b>Total GF Expenditures</b>	<b>2,089,785</b>	<b>5,346,719</b>	<b>3,256,934</b>	<b>39%</b>





<b>Table C (\$)</b>		
<b>GENERAL FUND COST CENTERS AS A PERCENTAGE TO ADOPTED FY 20/21 BUDGET</b>		
	<b>ADOPTED FY 20/21 BUDGET</b>	<b>% OF BUDGET</b>
<b>COST CENTER</b>		
Mayor/Council	65,576	1%
COURT	49,280	1%
TOWN MANAGER	146,530	3%
ADMINISTRATION	355,590	7%
Transfer to Other Funds	519,422	10%
FINANCE	140,001	3%
ATTORNEY	65,500	1%
TOWN CLERK	41,275	1%
COMMUNITY DEV	128,617	2%
INFORMATION TECH	59,689	1%
MAINTENANCE	122,211	3%
MCSO	2,056,429	38%
FIRE	1,337,907	25%
CEMETERY	22,124	0%
PARKS	182,431	3%
LIBRARY	10,818	0%
CAPITAL OUTLAY	43,319	1%
<b>Total Expenditure</b>	<b>5,346,719</b>	<b>100%</b>

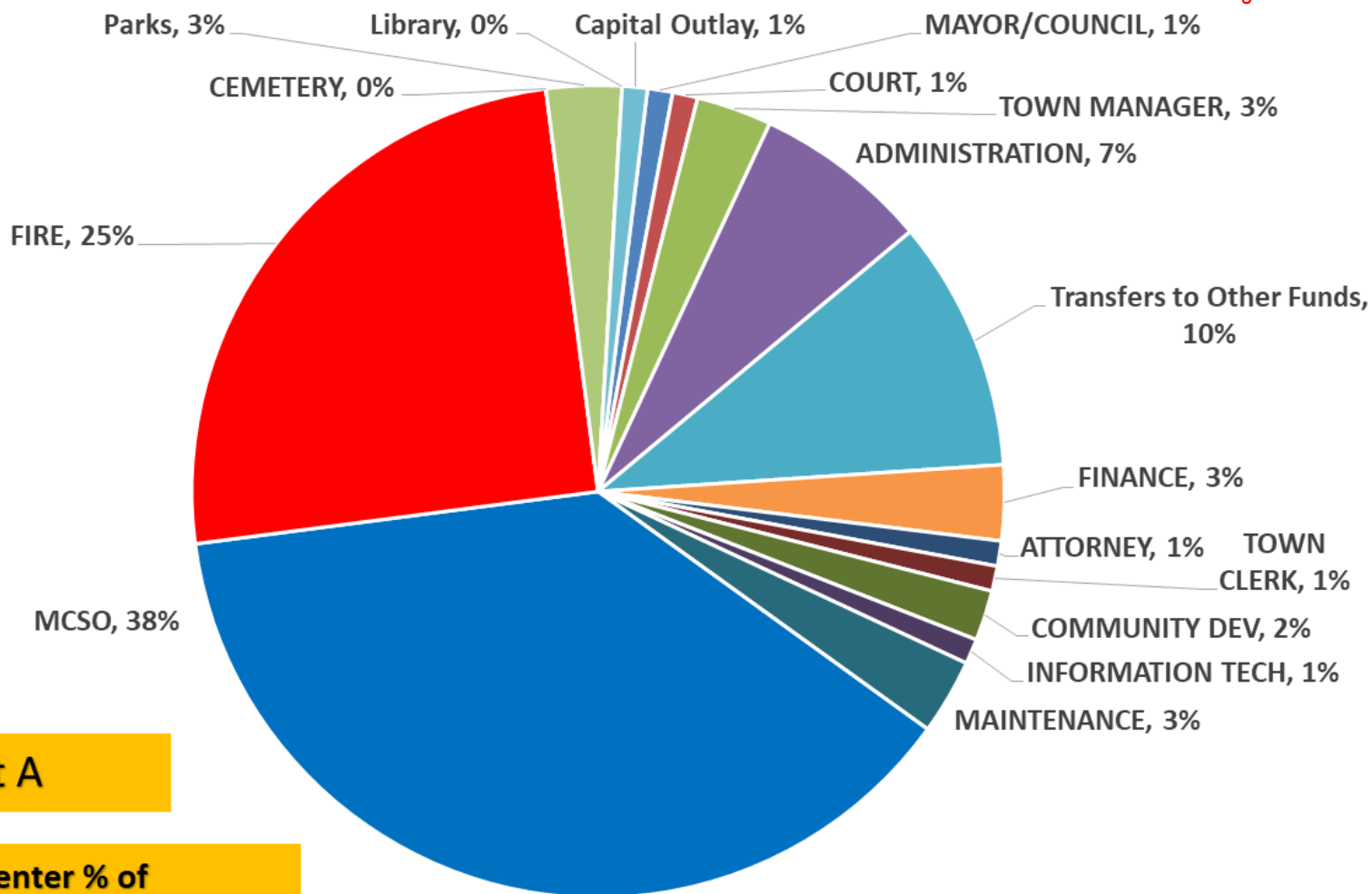

- MAYOR/COUNCIL
- COURT
- TOWN MANAGER
- ADMINISTRATION
- Transfers to Other Funds
- FINANCE
- ATTORNEY
- TOWN CLERK
- COMMUNITY DEV
- INFORMATION TECH
- MAINTENANCE
- MCSO
- FIRE
- CEMETERY
- Parks
- Library
- Capital Outlay

**Table D (\$)**

**PUBLIC SAFETY AND OTHER COST CENTER  
ADOPTED FY 20/21 BUDGET**

<b>COST CENTER</b>	<b>Adopted FY 20/21 Budget</b>	<b>% of Budget</b>
MAYOR/COUNCIL	65,576	1%
COURT	49,280	1%
TOWN MANAGER	146,530	3%
ADMINISTRATION	355,590	7%
TRANSFERS	519,422	10%
FINANCE	140,001	3%
ATTORNEY	65,500	1%
TOWN CLERK	41,275	1%
COMMUNITY DEV	128,617	2%
INFORMATION TECH	59,689	1%
MAINTENANCE	122,211	3%
POLICE	2,056,429	38%
FIRE	1,337,907	25%
CEMETERY	22,124	0%
PARKS	182,431	3%
LIBRARY	10,818	0%
CAPITAL OUTLAY	43319	1%
<b>Total Expenditure</b>	<b>5,346,719</b>	<b>100%</b>

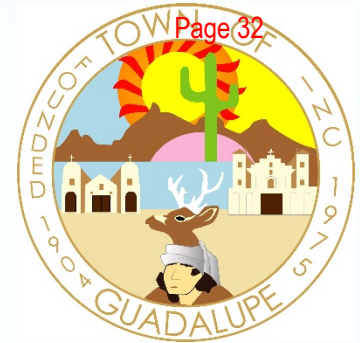

<b>MCSO</b>	<b>2,056,429</b>
<b>Fire</b>	<b>1,337,907</b>
<b>Total public safety</b>	<b>3,394,336</b>
<b>All others</b>	<b>1,952,383</b>





# PUBLIC SAFETY PORTION OF THE ADOPTED BUDGET 20/21

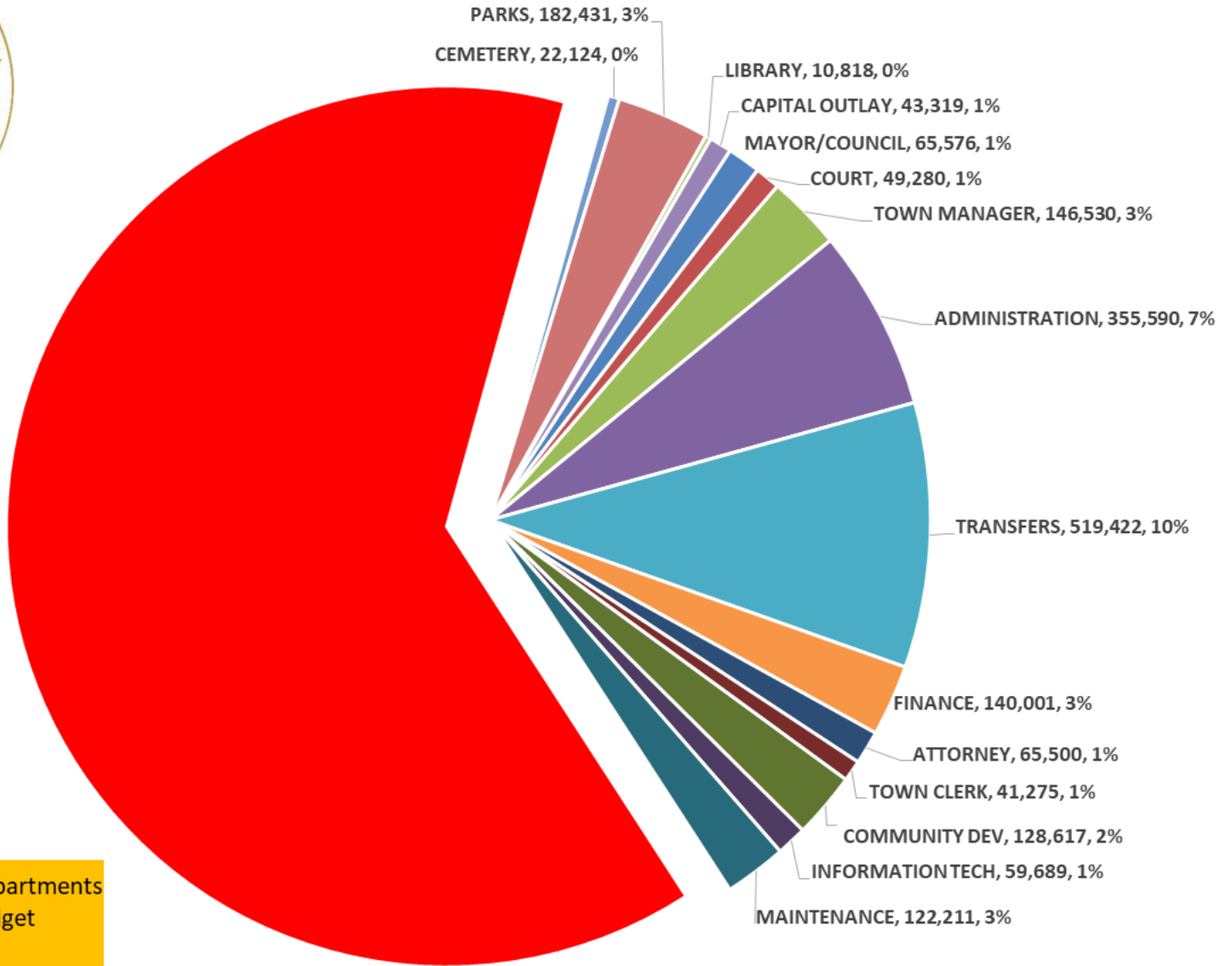

PUBLIC SAFETY, 3,394,336, 63%

## Chart B

Public Safety & Other Departments  
Total GF FY 20/21 Budget



# End of Year Actual & Projected Revenues & Expenses

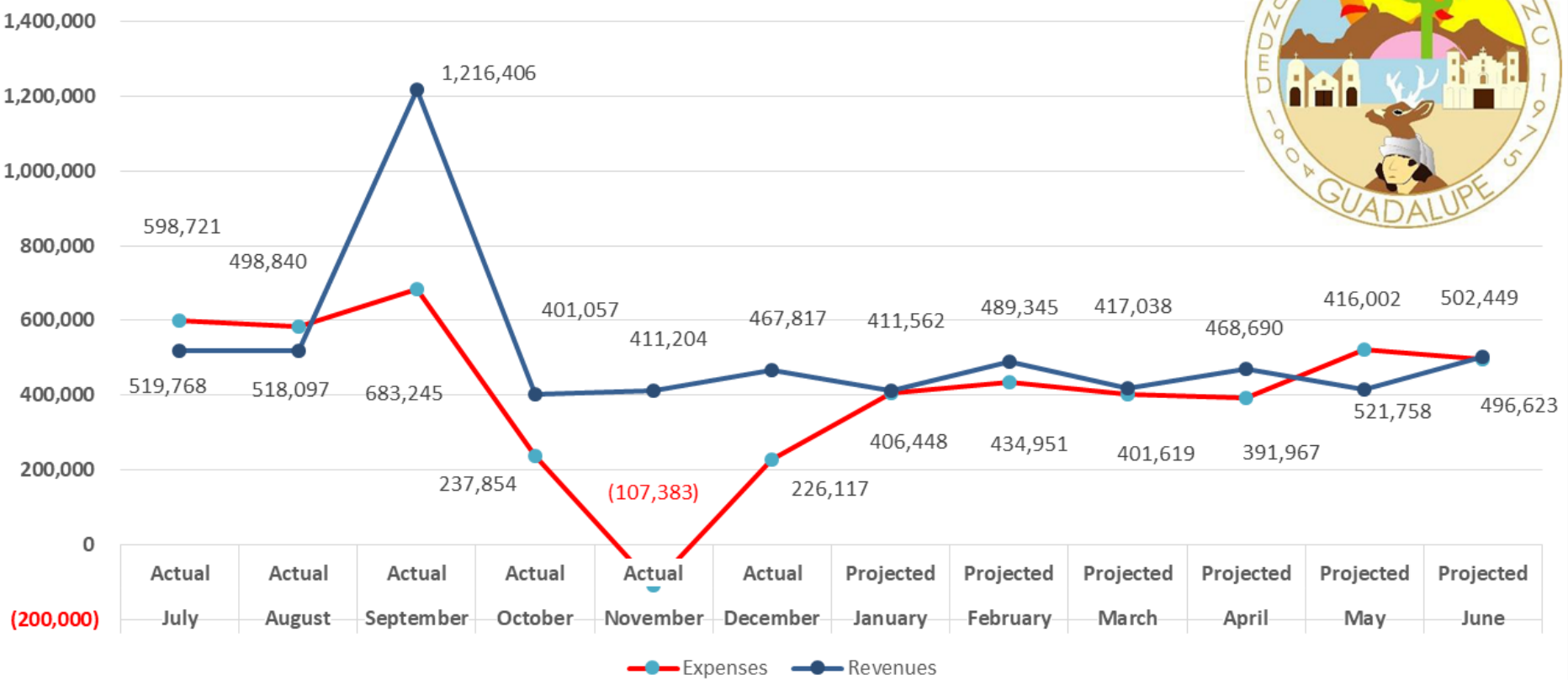

**Chart C**

## FY 20/21 General Fund Monthly Revenues & Expenditures Comparison



# General Fund Summary

Table E

<b>General Fund Take Aways - Mid Year FY 20/21</b>					
<b>Fund Analysis</b>	<b>Audited FY20</b>	<b>Adopted Budget FY20/21</b>	<b>Current Month</b>	<b>YTD Current 2021</b>	<b>YTD Projections</b>
<b>ACTUAL GENERAL FUND REVENUES</b>	\$5,260,497	\$5,028,238	\$467,817	\$3,316,097	\$6,239,436
<b>ACTUAL GENERAL FUND EXPENSES</b>	\$4,093,337	\$5,346,719	\$226,118	\$2,089,783	\$4,876,071
<b>ACTUAL Revenues / Expenditures</b>	\$1,167,160	-\$318,481	\$241,699	\$1,226,314	\$1,363,365
<b>Transfer to Other Funds</b>	<b>Audited FY20</b>	<b>Adopted Budget FY20/21</b>	<b>Current Month</b>	<b>YTD Current 2021</b>	<b>FY 2021 End of YR Projection</b>
Local Senior Transportation (LTAF)	\$20,641	\$21,443	\$4,249	\$19,361	\$24,500
Senior Center	\$87,034	\$97,075	\$2,768	\$33,890	\$83,000
Community Action Program	\$52,320	\$68,554	\$1,488	\$21,449	\$47,000
Municipal Property Corporation (Bond)	\$18,701	\$287,350	\$23,946	\$143,676	\$283,400
Grant Fund	\$0	\$45,000	\$0	\$0	\$45,000
State Cares Act	\$0	\$0	\$0	\$761,282	\$761,282
<b>Transfer to Other Funds Totals</b>	<b>\$178,696</b>	<b>519,422</b>	<b>\$32,451</b>	<b>\$979,458</b>	<b>\$1,244,182</b>

# General Fund Performance

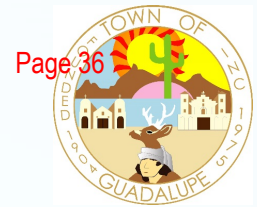

**General Fund Analysis FY17 - FY21**

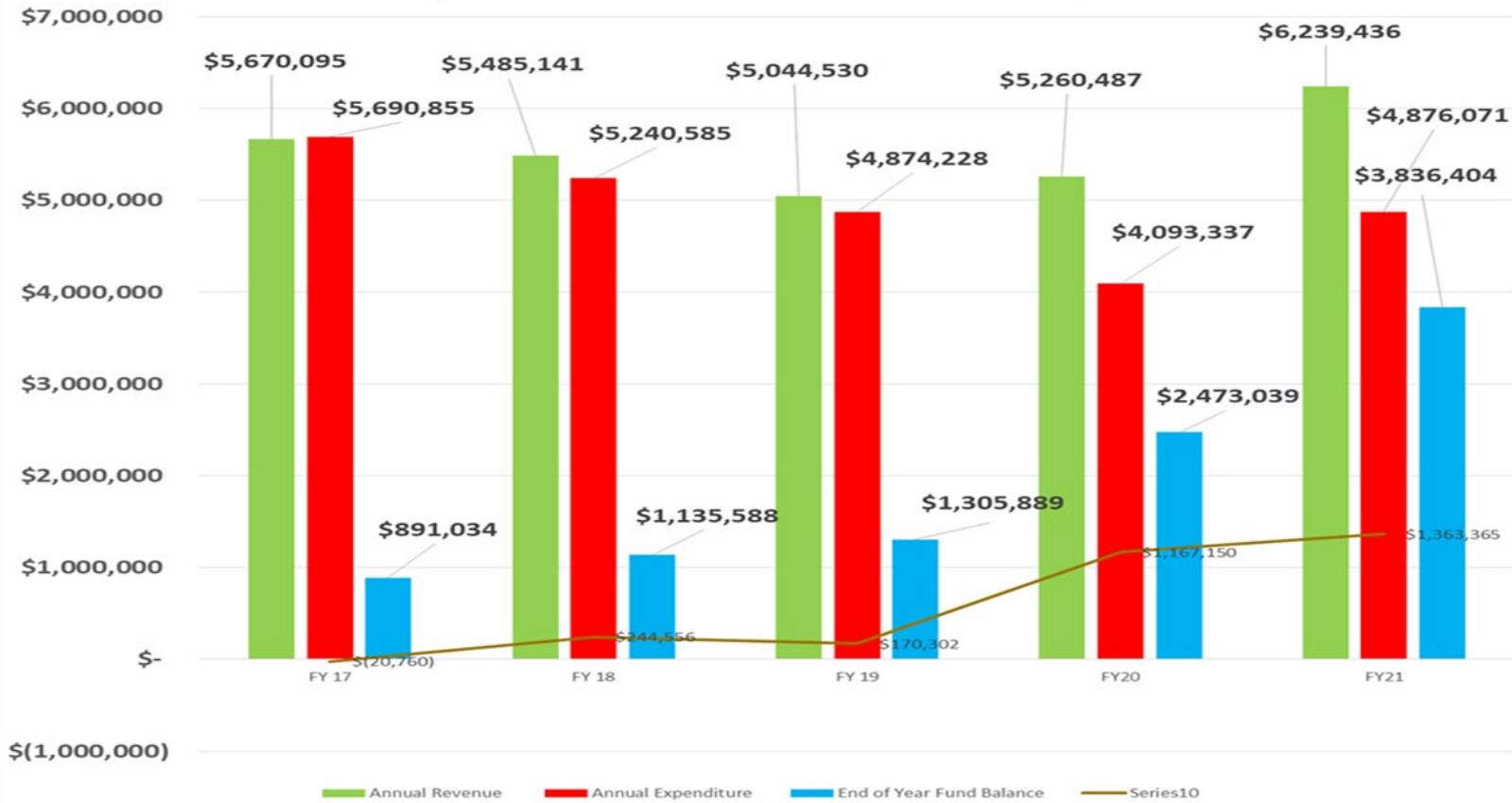

	Audited FY 17	Audited FY 18	Audited FY 19	Audited FY 20	Projected FY 21
Annual Revenues	\$5,670,095	\$5,485,141	\$5,044,530	\$5,260,487	\$6,239,436
Annual Expenditures	\$5,690,855	\$5,240,585	\$4,874,228	\$4,093,337	\$4,876,071
End of Year Fund Balance	\$891,034	\$1,135,588	\$1,305,889	\$2,473,039	\$3,836,404
Annual +/-	-\$20,760	\$244,556	\$170,302	\$1,167,150	\$1,363,365

Chart D

# General Fund: Building a Fund Balance But .....



Table F

Fund Balance	Audited FY20	Adopted Budget FY20	YTD Current 2021	FY 2021 END of YR x2 Projection	FY 2021 End of YR Refined Projection
Beginning Fund Balance	\$1,135,590	\$1,081,994	\$2,473,049	2,473,049	2,473,039
FY2020 Increase	\$170,300	-\$471,228	\$1,226,314	1,399,126	1,363,365
Ending Fund Balance	\$1,305,891	\$610,766	\$3,699,362	3,872,175	3,836,404

Analysis: Building a Fund Balance	But:
Capital replacement, repair, improvements:	St., s/w, canal, park, street lights, playground, st. signs, roofs, Mercado, Yard, FD,
ASRS & PSRS Pension Obligations:	\$1,097,158 & \$1,189,699 = \$2,286,857
Competitive Salaries:	No salary increases in 3 years & minimum wage compression
Level of Service Priorities:	Code Enforcement, Property Maint., Youth Development Programs, New Construction
Gov. Fin. Officers Assoc. recommends Fund Balance of :	25% or 3 months of expenditures = approx. \$1,3376,670

Investment in resources:  
facilities and people continue to fall behind.

# Special Revenue Funds: HURF & LTAF



Table G				
HURF YTD - thru Dec 2020	Audited FY 2020	Adopted FY 2021	YTD Current	% of FY 20/21 Budget
HURF Revenues YTD	\$643,129	\$462,056	\$219,023	47%
HURF Expenditures YTD	(\$421,823)	(\$613,858)	(\$252,244)	41%
REVENUES OVER (UNDER) EXPENDITURES	\$221,306	(\$151,802)	(\$33,221)	22%
HURF FUND BALANCE				
HURF FUND BALANCE	Audited FY 2020	Adopted FY 2021	YTD Current	% of FY 20/21 Budget
Transfers From General Fund	\$0	\$0	\$0	
Fund Balance Carryforward	\$0	\$151,802	\$33,221	22%
BEGINNING FUND BALANCE	NA	\$167,909	\$221,306	132%
ENDING FUND BALANCE	\$221,306	\$16,107	\$188,085	1168%
Table H				
LTAf YTD - thru Dec 2020	Audited FY 2020	Adopted FY 2021	YTD Current	% of FY 20/21 Budget
LTAf Revenues YTD	\$16,740	\$16,601	\$0	0%
LTAf Expenditures YTD	(\$37,381)	(\$38,044)	(\$19,360)	51%
REVENUES OVER (UNDER) EXPENDITURES	(\$20,641)	(\$21,443)	(\$19,360)	90%
LTAf FUND BALANCE				
LTAf FUND BALANCE	Audited FY 2020	Adopted FY 2021	YTD Current	% of FY 20/21 Budget
Transfers From General Fund	\$20,641	\$21,443	\$19,360	90%
BEGINNING LTAf FUND BALANCE	\$0	\$0	\$0	
ENDING LTAf FUND BALANCE	\$0	\$0	\$0	

# Special Revenue Funds: Senior Center & CAP



**Table I**

SENIOR YTD - thru Dec 2020	Audited FY 2020	Adopted FY 2021	YTD Current	% of FY 20/21 Budget
Senior Center Revenues YTD	\$144,645	\$144,488	\$73,554	51%
Senior Center Expenses YTD	(\$231,678)	(\$241,563)	(\$107,241)	44%
REVENUES OVER (UNDER) EXPENDITURES	(\$87,033)	-(97,075)	(\$33,687)	35%
<b>SENIOR CENTER FUND BALANCE</b>				
Transfers From General Fund	\$87,033	\$97,075	\$33,687	35%
BEGINNING FUND BALANCE	\$0	\$0	\$0	
ENDING FUND BALANCE	\$0	\$0	\$0	

**Table J**

CAP YTD - thru Dec 2020	Audited FY 2020	Adopted FY 2021	YTD Current	% of FY 20/21 Budget
CAP Revenues YTD	\$59,141	\$115,000	\$28,485	25%
CAP Expenses YTD	(\$149,777)	(\$143,554)	(\$49,933)	35%
REVENUES OVER (UNDER) EXPENDITURES	(\$90,636)	(\$68,554)	(\$21,448)	31%
<b>CAP FUND BALANCE</b>				
Transfers From General Fund	\$90,636	\$68,554	\$21,448	31%
BEGINNING FUND BALANCE	\$0	\$0	\$0	
ENDING FUND BALANCE	\$0	\$0	\$0	



# Special Revenue Funds: CARES Act: PYT & State

Table K			
COVID YTD - thru Dec 2020	Audited FY 2020	Adopted FY 2021	YTD Current
PYT COVID GRANT Revenues YTD	\$0	\$0	\$2,002,497
PYT COVID GRANT Expenses YTD	(\$23,094)	\$0	(\$2,025,387)
REVENUES OVER (UNDER) EXPENDITURES	(\$23,094)	\$0	(\$22,890)
PYT COVID FUND BALANCE	Audited FY 2020	Adopted FY 2021	YTD Current
Transfers From General Fund	\$0	\$0	\$0
BEGINNING FUND BALANCE	\$0	\$0	(\$23,094)
ENDING FUND BALANCE	(\$23,094)	\$0	(\$45,984)
Table L			
STATE-AZ CARES thru Dec 2020	Audited FY 2020	Adopted FY 2021	YTD Current
State-AZ CARES Act Revenues YTD	\$0	\$0	\$761,282
State-AZ CARES Act Expenses YTD	(\$493,092)	\$0	(\$268,190)
REVENUES OVER (UNDER) EXPENDITURES	(\$493,092)	\$0	\$493,092
State-AZ CARES FUND BALANCE	Audited FY 2020	Adopted FY 2021	YTD Current
Transfers From General Fund	\$0	\$0	\$0
BEGINNING FUND BALANCE	\$0	\$0	(\$493,092)
ENDING FUND BALANCE	(\$493,092)	\$0	\$0



# Special Revenue Funds: MPC Bond Payment



Table M

MPC BOND YTD - thru Dec 2020	Audited FY 2020	Adopted FY 2021	YTD Current	% of FY 20/21 Budget
MPC Revenues YTD	\$0	\$0	\$0	\$0
MPC Expenses YTD	(\$18,701)	\$287,350	\$143,675	50%
REVENUES OVER (UNDER) EXPENDITURES	(\$18,701)	\$287,350	\$143,675	50%
<b>MPC BOND FUND BALANCE</b>				
MPC BOND FUND BALANCE	Audited FY 2020	Adopted FY 2021	YTD Current	
Transfers From General Fund	\$18,701	\$287,350	\$143,675	
BEGINNING FUND BALANCE	\$0	\$0	\$0	
ENDING FUND BALANCE	\$0	\$0	\$0	

Table N

Transfer to Other Funds	Audited FY20	Adopted Budget FY2021	YTD Current 2021	FY 2021 End of YR Transfers Projected
Local Senior Transportation (LTAF)	\$20,641	\$21,443	\$19,361	\$24,500
Senior Center	\$87,034	\$97,075	\$33,690	\$83,000
Community Action Program	\$52,320	\$68,554	\$21,449	\$47,000
Municipal Property Corporation(Bond)	\$18,701	\$287,350	\$143,676	\$283,400
Grant Fund	\$0	\$45,000	\$0	\$45,000
State Cares Act	\$0	\$0	\$761,282	\$761,282
Transfer to Other Funds Totals	\$178,696	\$519,422	\$979,458	\$1,244,182



# Enterprise Fund: Mercado

Table O				
MERCADO YTD	Audited FY 2020	YTD Current	% of FY Budget	Adopted FY 2021
Mercado Revenues YTD	\$165,249	\$78,907	47%	\$168,180
Mercado Expenditures YTD	(\$142,247)	(\$81,477)	46%	(\$178,949)
<b>REVENUES OVER (UNDER) EXPENDITURES</b>	\$23,002	(\$2570)		(\$10,769)
MERCADO FUND BALANCE	Audited FY 2020	YTD Current		Adopted FY 2021
Transfers From General Fund	\$0	\$0		\$0
BEGINNING FUND BALANCE – Net Position	\$26,019	\$49,021		\$32,294
Prior Year Funds earned/(used)	\$0	(\$2,570)		(\$10,769)
<b>ENDING FUND BALANCE - Net Position</b>	\$49,021	\$46,451		\$21,525

# Enterprise Fund: Wastewater / Sewer

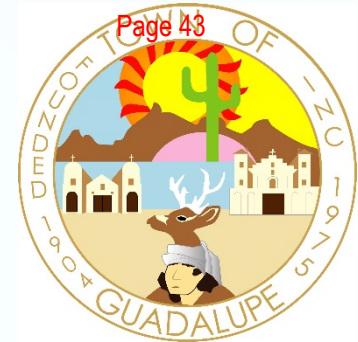

Table P				
SEWER FUND YTD	Audited FY 2020	YTD Current	% of Budget	Adopted FY 2021
Sewer Revenues YTD	\$98,523	\$56,394	9%	\$634,397
Sewer Expenditures YTD	(\$394,731)	(\$67,651)	10%	(\$666,685)
REVENUES OVER (UNDER) EXPENDITURES	(\$296,208)	(\$11,257)		(\$32,288)
SEWER FUND BALANCE	Audited FY 2020	YTD Current		Adopted FY 2021
Transfers From General Fund	\$0	\$0		\$0
BEGINNING FUND BALANCE - Net Position	\$1,274,652	\$978,445		\$638,262
Prior Year Funds earned/(used)	(\$296,207)	(\$11,257)		(\$32,288)
ENDING FUND BALANCE - Net Position	\$978,445	\$967,188		\$605,974



# Enterprise Fund: Solid Waste

Table Q				
SOLID WASTE FUND YTD	Audited FY 2020	YTD Current	% of Budget	Adopted FY 2021
Solid Waste Revenues YTD	\$305,594	\$137,068	51%	\$297,306
Solid Waste Expenditures YTD	(\$363,873)	(\$124,670)	46%	\$275,911
<b>REVENUES OVER (UNDER) EXPENDITURES</b>	<b>(\$58,279)</b>	<b>\$12,398</b>		<b>\$23,395</b>
SOLID WASTE FUND BALANCE	Audited FY 2020	YTD Current		Adopted FY 2021
Transfers From General Fund	\$0	\$0		\$0
BEGINNING FUND BALANCE - Net Position	\$275,363	\$217,084		\$127,956
Prior Year Funds earned/(used)	(\$58,279)	\$12,398		\$21,395
<b>ENDING FUND BALANCE - Net Position</b>	<b>\$217,084</b>	<b>\$229,482</b>		<b>\$149,351</b>

# In summary: FY 2020/21 Mid Year Budget Report



## General Fund:

- Revenues exceed expenditures: 4 straight years
- Fund Balance: \$891K to \$3.8M
- Building financial stability
- Current \$5.3M adopted budget provides for current levels of services and upkeep.
- The current \$5.4M does not allow for needed repair, added service levels, reducing liability.
- **CAUTION: Moving in stable financial direction.**
- **However, without recurring stable revenue streams:**
- **The Town of Guadalupe will continue facing fiscal struggles**
- **And without eliminating direct services, there is nothing left to cut.**

# In summary: FY 2020/21 Mid Year Budget Report

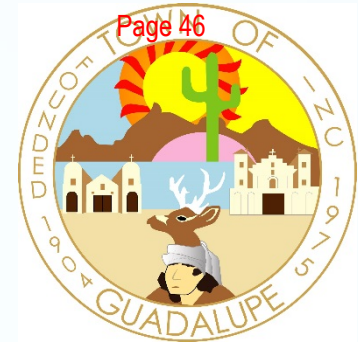

## Ten Other Funds:

- |                       |          |                                     |
|-----------------------|----------|-------------------------------------|
| 1. HURF:              | in check | relies on General Fund transfers    |
| 2. LTAF               | in check | relies on General Fund transfers    |
| 3. Senior Center      | in check | relies on General Fund transfers    |
| 4. CAP                | in check | relies on General Fund transfers    |
| 5. MPC Bond           | in check | relies on General Fund transfers    |
| 6. CARES Act – PYT    | complete | concluded December 2020             |
| 7. CARES Act – State  | complete | concluded December 2020             |
| 8. Mercado            | concern  | fund balance approaching \$0.00     |
| 9. Sewer / Wastewater | concern  | repair, replacement needs continue  |
| 10. Solid Waste       | concern  | after 12 years, rate hike is needed |



***Thank you  
&  
Questions***

***February 25, 2021***

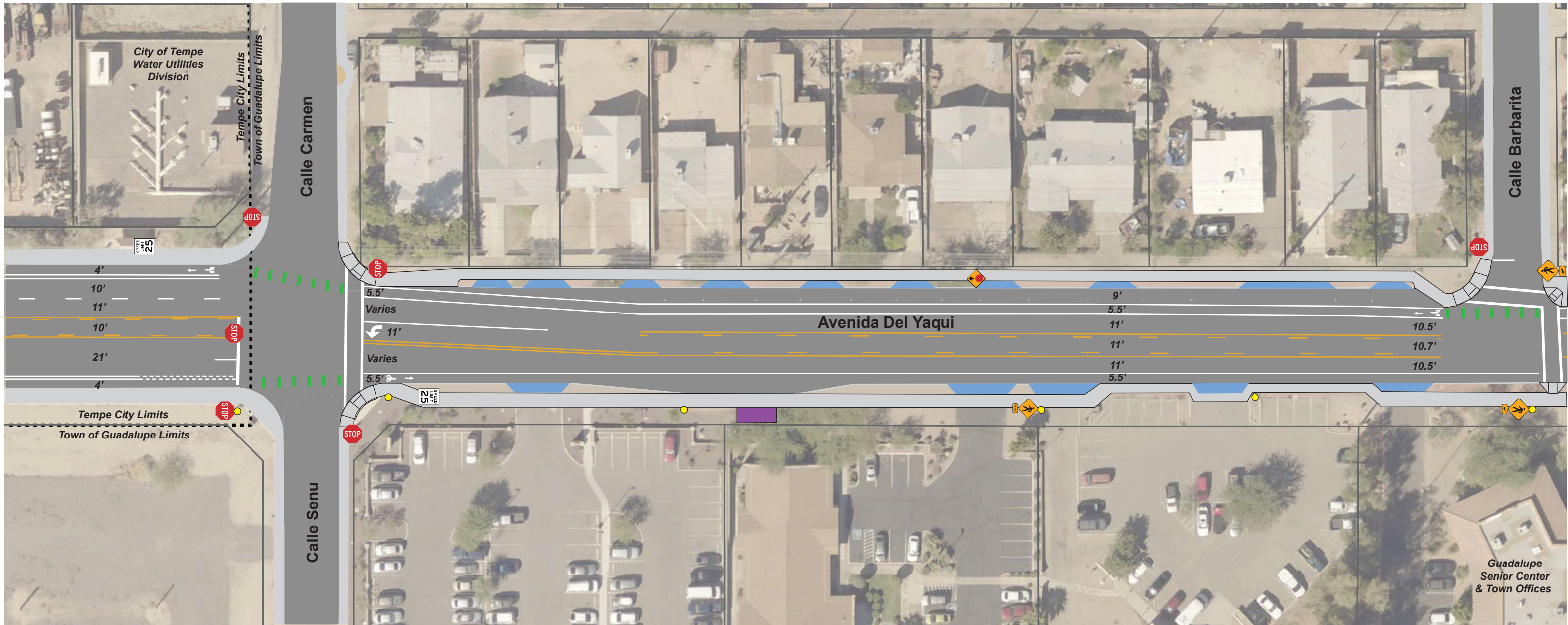

### LEGEND

- Asphalt Roadway
- Concrete Sidewalk
- Bicycle Lane
- Driveway
- XX'** Lane Width
- Roll Curb
- Existing Transit Stop - Structure
- Existing Transit Stop - No Structure
- Street Light
- Parcel Boundary
- Town Limits

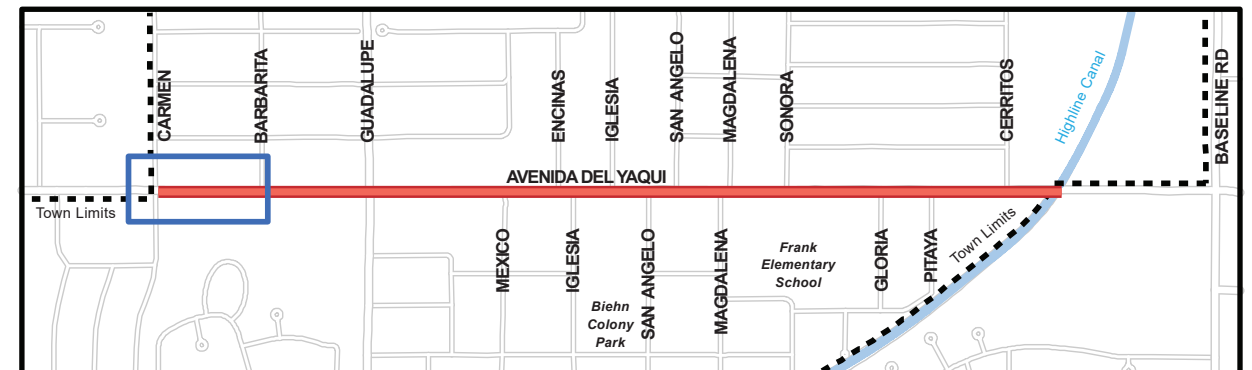

Preliminary

Segment 1 of 8





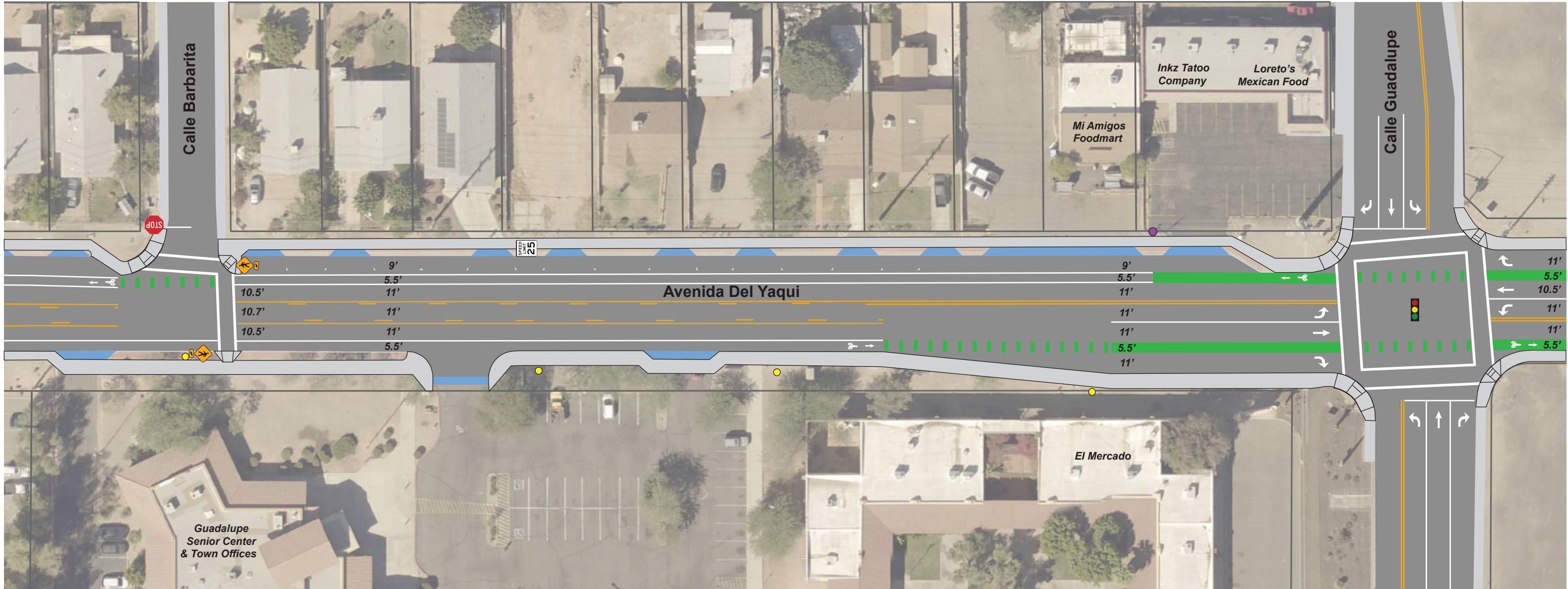

### LEGEND

- Asphalt Roadway
- Concrete Sidewalk
- Bicycle Lane
- Driveway
- XX'** Lane Width
- Roll Curb
- Existing Transit Stop - Structure
- Existing Transit Stop - No Structure
- Street Light
- Parcel Boundary
- Town Limits



Preliminary

Segment 2 of 8



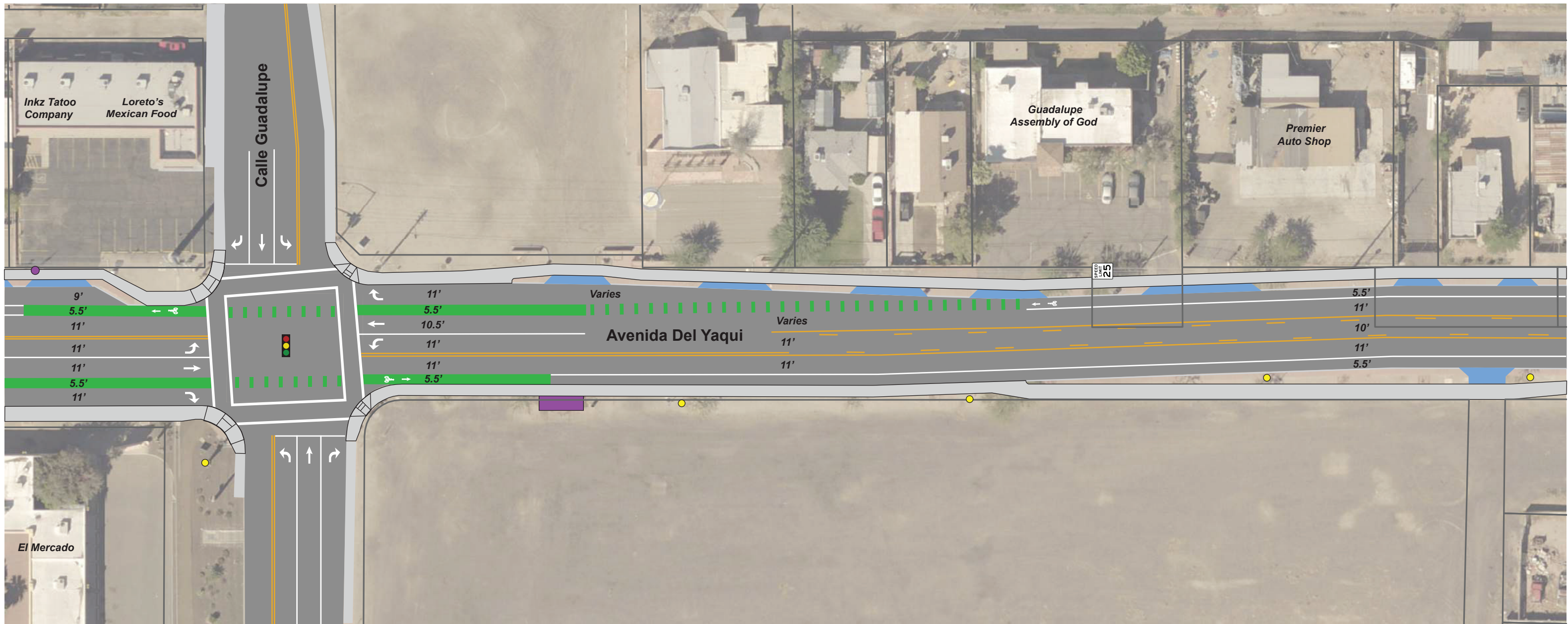

### LEGEND

- Asphalt Roadway
- Concrete Sidewalk
- Bicycle Lane
- Driveway
- XX'** Lane Width
- Roll Curb
- Existing Transit Stop - Structure
- Existing Transit Stop - No Structure
- Street Light
- Parcel Boundary
- Town Limits

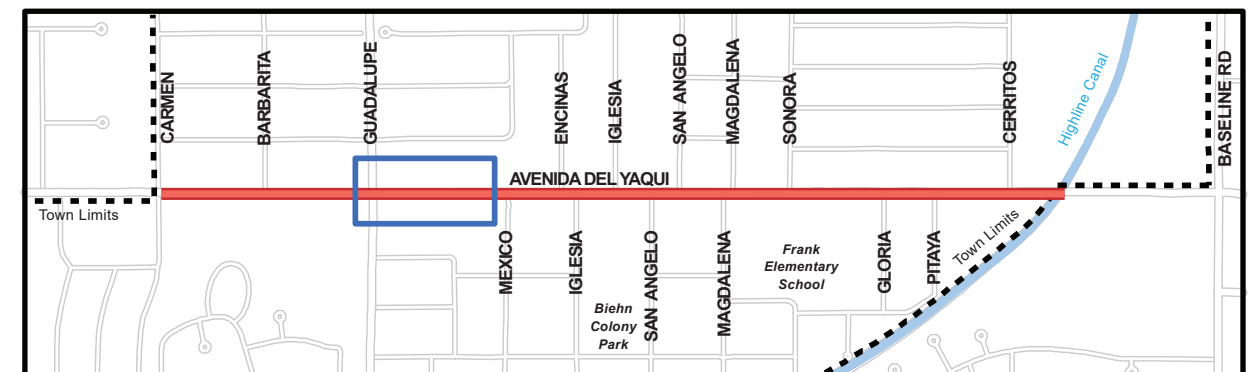

Preliminary

Segment 3 of 8



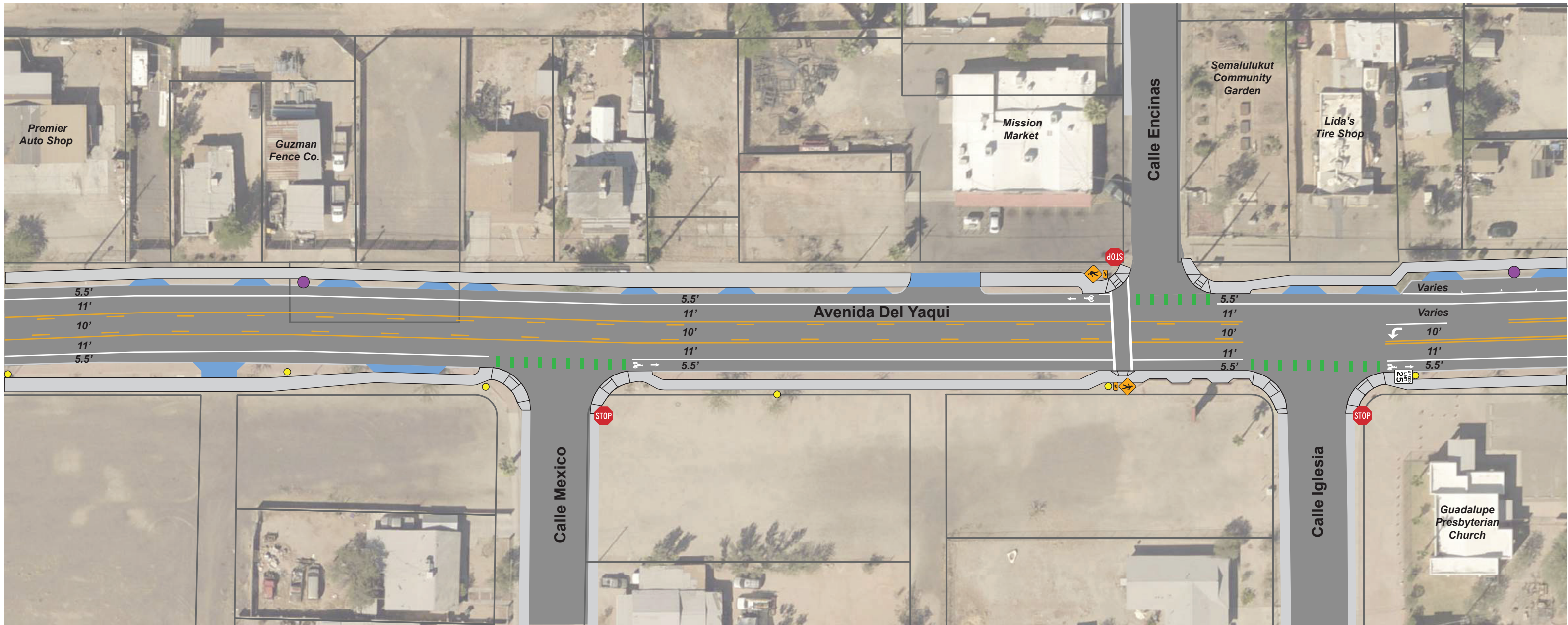

### LEGEND

- Asphalt Roadway
- Concrete Sidewalk
- Bicycle Lane
- Driveway
- XX'** Lane Width
- Roll Curb
- Existing Transit Stop - Structure
- Existing Transit Stop - No Structure
- Street Light
- Parcel Boundary
- Town Limits

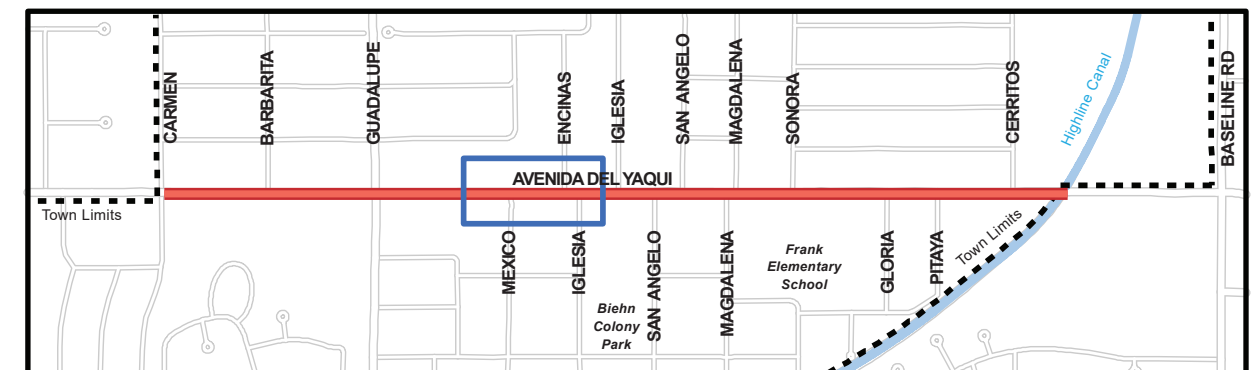

Preliminary

Segment 4 of 8

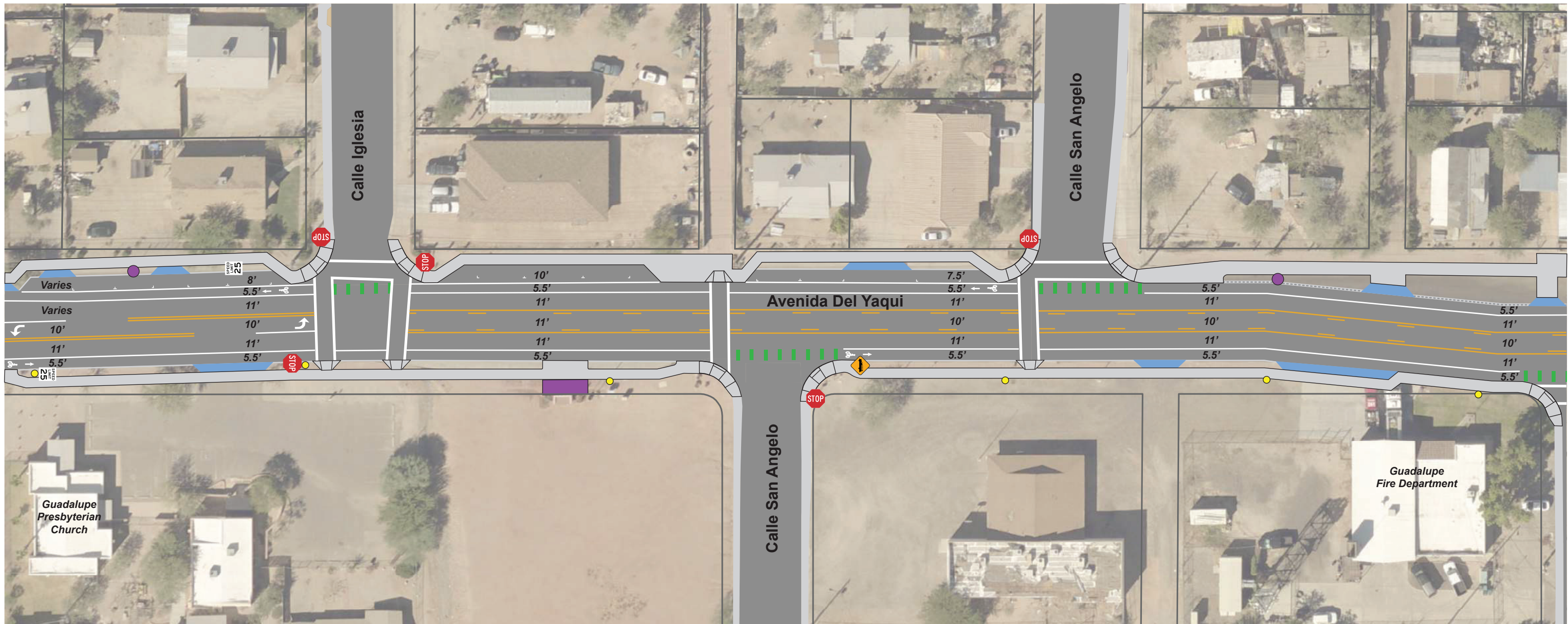

### LEGEND

- Asphalt Roadway
- Concrete Sidewalk
- Bicycle Lane
- Driveway
- XX'** Lane Width
- Roll Curb
- Existing Transit Stop - Structure
- Existing Transit Stop - No Structure
- Street Light
- Parcel Boundary
- Town Limits

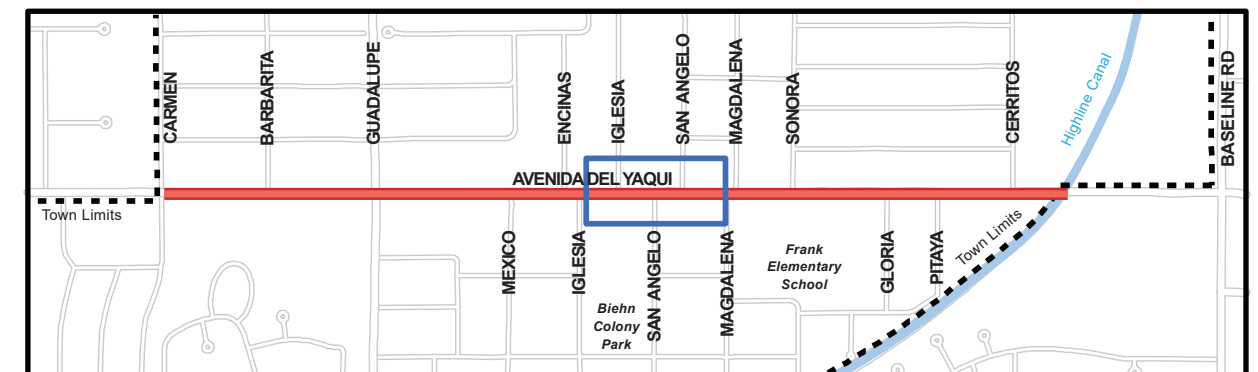

Preliminary

Segment 5 of 8





### LEGEND

- Asphalt Roadway
- Concrete Sidewalk
- Bicycle Lane
- Driveway
- XX'** Lane Width
- Roll Curb
- Existing Transit Stop - Structure
- Existing Transit Stop - No Structure
- Street Light
- Parcel Boundary
- Town Limits

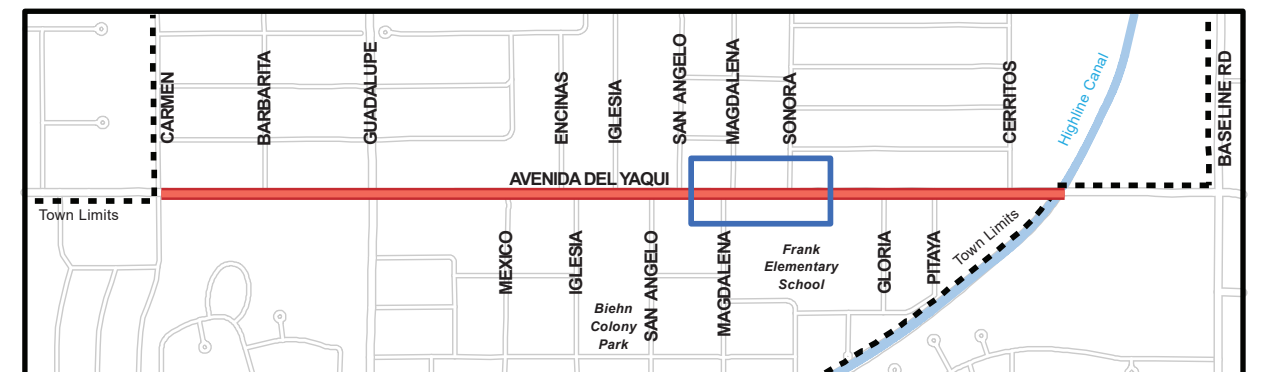

Preliminary

Segment 6 of 8

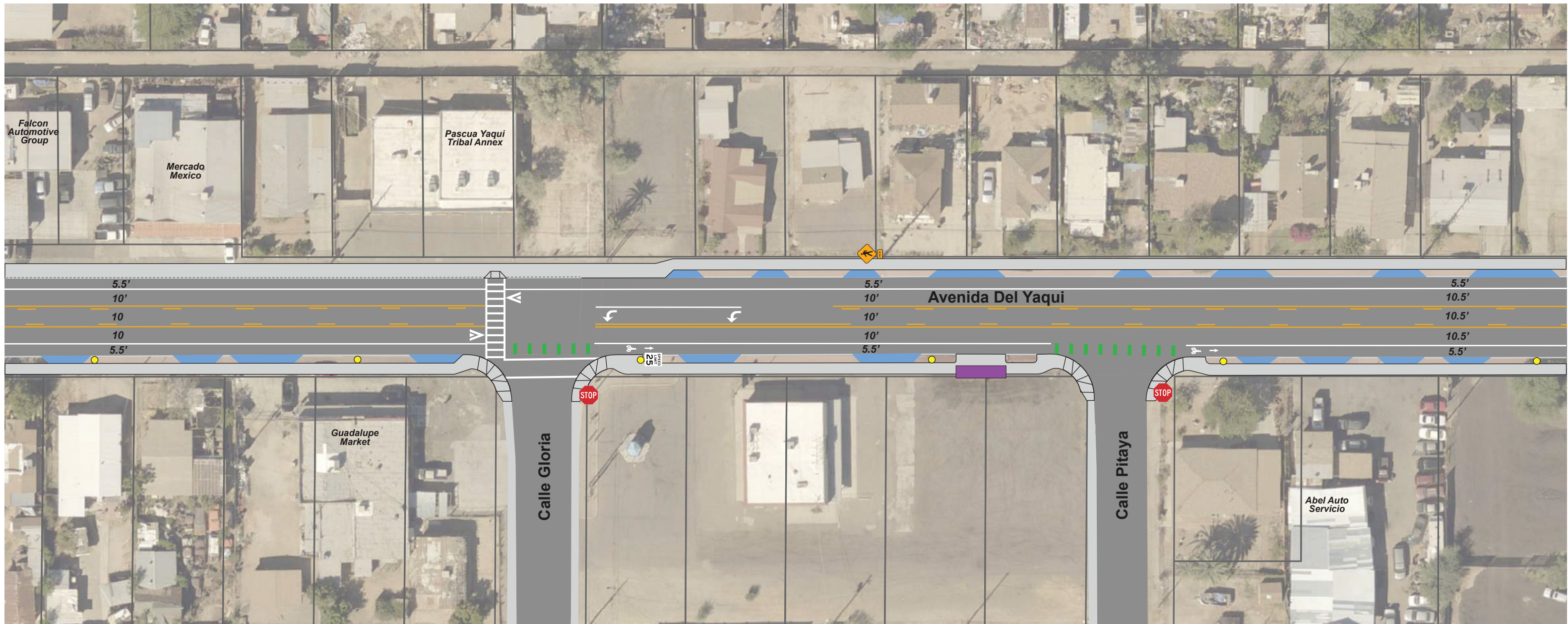

### LEGEND

- Asphalt Roadway
- Concrete Sidewalk
- Bicycle Lane
- Driveway
- XX'** Lane Width
- Roll Curb
- Existing Transit Stop - Structure
- Existing Transit Stop - No Structure
- Street Light
- Parcel Boundary
- Town Limits

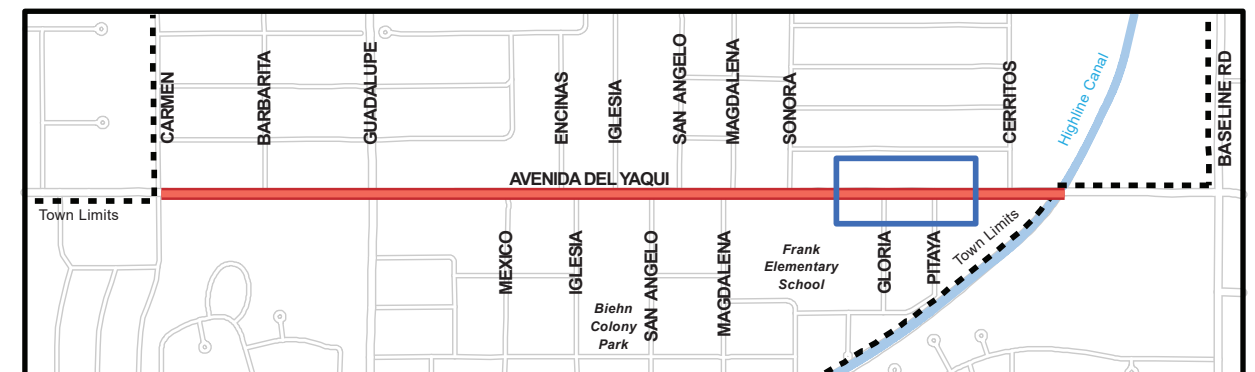

Preliminary

Segment 7 of 8



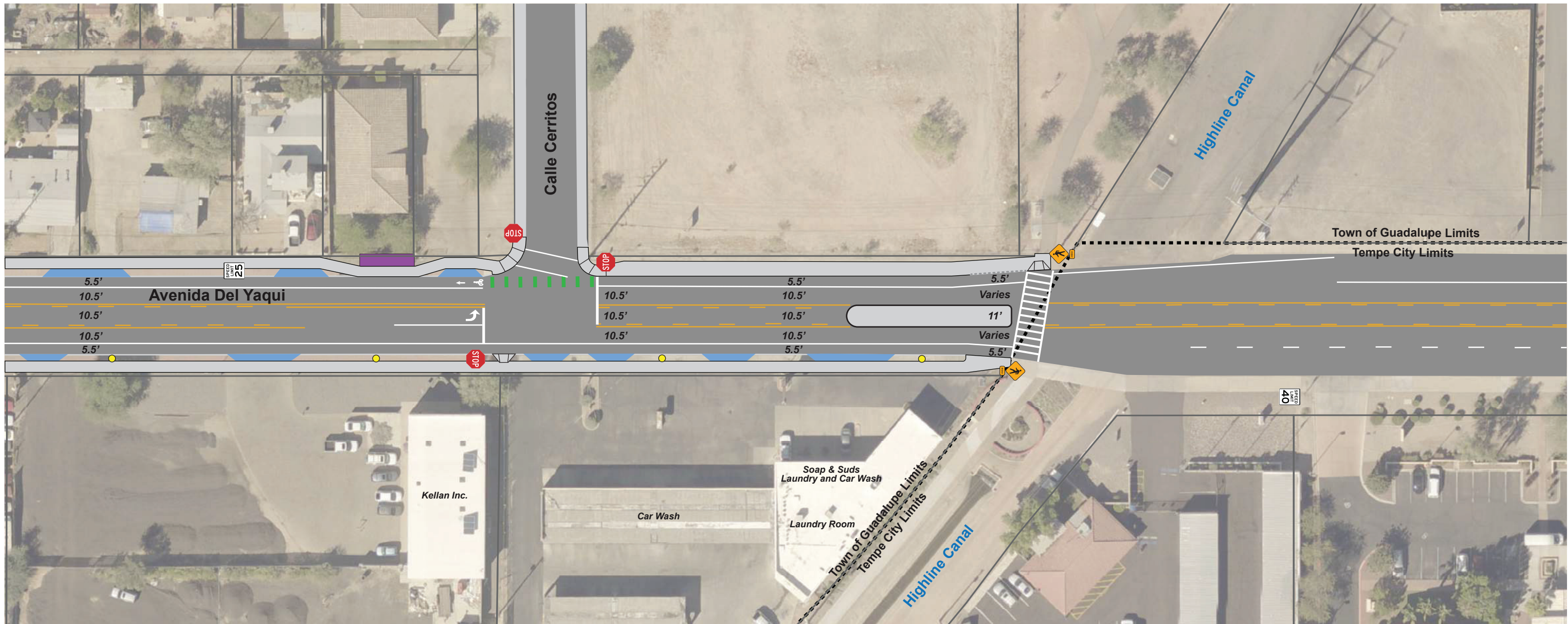

### LEGEND

- Asphalt Roadway
- Concrete Sidewalk
- Bicycle Lane
- Driveway
- XX'** Lane Width
- Roll Curb
- Existing Transit Stop - Structure
- Existing Transit Stop - No Structure
- Street Light
- Parcel Boundary
- Town Limits

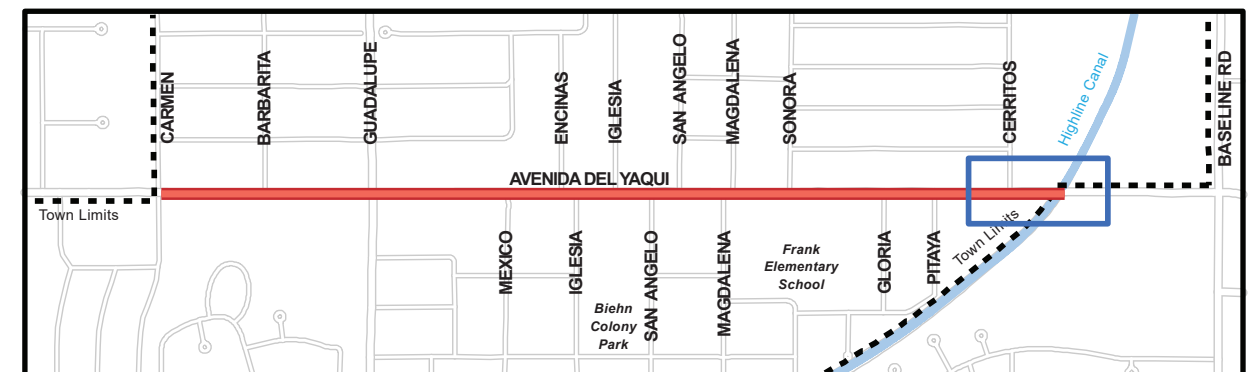

Preliminary

Segment 8 of 8





## Town of Guadalupe Public Meeting – August 15, 2018

The Town of Guadalupe held a town open house on Wednesday August 15, 2018 to seek public input on the Avenida del Yaqui bicycle and pedestrian improvement project. The project is in the early stages of design, and public input is being used to determine the direction the town prefers for various design alternatives.

Outreach efforts to the public included distributing flyers to the town, posting information about the event on the town calendar and website, and going door-to-door informing residents within the project limits. In total there were 24 people in attendance at the open house, along with supporting town staff members. Of the 24 people who signed in, 21 were town residents. The sign-in sheet is attached.

To start the open house off, Jeff Kulaga introduced the project and consultant team. Yung with Y2K Engineering provided a background of the project status at this point and the next steps. She explained how public input would be collected and the importance of the meeting. Yung then briefly went over the 12 design elements and their alternatives.

After the introduction to the project and an overview of the design elements and alternatives was presented, the public was invited to provide their input and ask questions. There are 12 design elements that the public was asked to evaluate. Each element has an image of the existing condition and three potential improvements. Everyone was given 12 green stickers to put on the design elements they preferred.

To determine the design elements that the town most valued, all attendees were given five dollar sign stickers. They were asked to place their “money” where they felt the budget should be spent and what funding should prioritize. Residents were also invited to provide additional comments and suggestions using sticky notes.

A spreadsheet summarizing the preferences indicated by the public and pictures of the boards from the open house are attached.

The major take aways are as follows:

- There were multiple concerns about the safety of the transit stops, and bus bulb-outs along the corridor, specifically at the intersection of Avenida del Yaqui and Calle Guadalupe.
- Multiple residents expressed wanting to see pedestrian crossings on the corridor, specifically at the school and near the intersection with Calle Guadalupe.





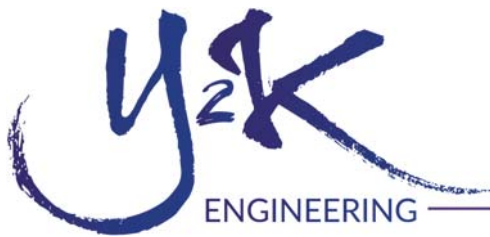

- Based on the allocation of the green stickers, raised crosswalks, no on street-parking, and concrete bike lanes were the most popular design alternatives.
- Based on the allocation of the money stickers the bike environment, sidewalk and parking are the design elements that the Town of Guadalupe is the most invested in.

General comments from the attendees are recorded below:

- Enforce no semi-trucks to pass through town, they ruin our streets
- Business parking is blocking sidewalk
- Bus stops: Lighting solar, color – brighter as our community, blues or earth tones
- Banner hanger on light poles
- Community bulletin boards
- Better bus pull-out at intersections of Avenida del Yaqui/Guadalupe and Avenida del Yaqui/Cerritos
- Work with Valley Metro in adding curb bus stops
- School crossing safety
- Flashing pedestrian walk across from town hall
- Good bright lighting for crosswalks



<b>G</b>	<b>\$</b>	<b>Improvement</b>	<b>Alternative</b>	<b>Green</b>	<b>\$</b>	<b>Comments</b>
16	5	Sidewalk Expansion Joints	Existing	0	0	
			8' Sidewalk with 4'X4' Colored Concrete	2	1	
				14	4	
			Decorative Concrete Joints	0	0	
26	14	Sidewalk	Existing	2	1	
			Attached Sidewalk	4	3	
			Attached Sidewalk + Landscape	1	0	
			Detached Sidewalk + Landscape	19	10	
30	18	Bike Environment	Existing	0	0	
			Bike Lane + Curb and Gutter	5	0	
			Green Bike Lane Segments	4	0	
			Concrete Bike Lane	21	18	
17	11	Transit Stop	Existing	6	7	Artwork incorporated with design, relocate bus stops near crossroads
			Enhanced Transit Stop I	6	0	
			Enhanced Transit Stop II	0	0	
			Enhanced Transit Stop III	5	4	But beautiful/colorful
19	3	Trees	Existing Ficus Trees	1	0	
			Mulga	0	0	
			Chaste Tree	15	3	
			Evergreen Ash	3	0	
13	5	Landscape	Existing	0	0	
			Native Landscape	2	0	
			Enhanced Native Landscape	8	4	
			Enhanced Cactus Landscape	3	1	
24	9	Crosswalk	Existing	0	0	New crosswalk for senior center crossing
			Painted Crosswalk Lines	2	0	
			Colored Crosswalk	0	0	
			Raised Crosswalk	22	9	Midblock raised crosswalk for school between sonora & magdalena w/ flashing lights
40	13	Parking	Existing Parking	0	0	
			No Parking-Enhanced Landscape	22	7	
			On Street Parking	0	0	

			Enhanced on Street Parking	18	6	
19	6	<b>Seating</b>	Existing	0	0	Garbage cans
			Single Seat Chairs	1	0	
			Concrete Bench	0	0	If concrete bench, light/white color for cool to touch
			Gabion Seat Wall	18	6	
25	3	<b>Bike Parking Facilities</b>	Existing	0	0	
			Wave Bike Rack	8	0	
			Enhanced Bike Rack I	17	3	Make secure for bike, hard to take pieces of bike
			Enhanced Bike Rack II	0	0	
21	7	<b>Lighting</b>	Existing	3	1	On the new street lights can electrical outlets be added on the upper section for future light decoration for the holidays? Solar panels
			Enhanced Lighting I	9	3	Please add banner holder
			Enhanced Lighting II	9	3	
			Enhanced Lighting III	3	4	
			3000K Amber Lighting	1	0	
			4000K White Lighting	17	2	

# Town of Guadalupe Avenida Del Yaqui Bicycle and Pedestrian Improvement Project

EXISTING CONDITIONS



EXISTING SIDEWALK EXPANSION JOINTS

PROPOSED SOLUTIONS



8' SIDEWALK WITH 4' x 4'



COLORED CONCRETE



DECORATIVE CONCRETE JOINTS



EXISTING SIDEWALK



ATTACHED SIDEWALK



ATTACHED SIDEWALK + LANDSCAPE



DETACHED SIDEWALK + LANDSCAPE

PROPOSED IMAGERY  
LS 1.0



JACOBS

# Town of Guadalupe

Avenida Del Yaqui Bicycle and Pedestrian Improvement Project

EXISTING CONDITIONS



EXISTING BIKE ENVIRONMENT



EXISTING TRANSIT STOP - NO STRUCTURE

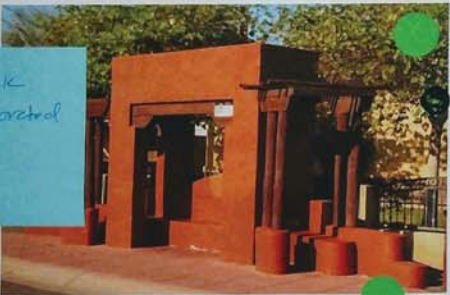

EXISTING STRUCTURES TO REMAIN

PROPOSED SOLUTIONS



BIKE LANE + CURB AND GUTTER



GREEN BIKE LANE SEGMENTS



CONCRETE BIKE LANE



ENHANCED TRANSIT STOP



ENHANCED TRANSIT STOP



ENHANCED TRANSIT STOP

PROPOSED IMAGERY  
LS 1.1

Relocate the Bus Stop (Midea) near Crossroads

But Beautiful Colorful



# Town of Guadalupe

Avenida Del Yaqui Bicycle and Pedestrian Improvement Project

EXISTING CONDITIONS



EXISTING TREES  
FICUS TREES TO REMAIN

PROPOSED SOLUTIONS



THEME TREE - MULGA



THEME TREE - CHASTE TREE



THEME TREE - EVERGREEN ASH



EXISTING LANDSCAPE



NATIVE LANDSCAPE



ENHANCED NATIVE LANDSCAPE



ENHANCED CACTUS LANDSCAPE

PROPOSED IMAGERY  
LS 1.2



JACOBS

# Town of Guadalupe

## Avenida Del Yaqui Bicycle and Pedestrian Improvement Project

EXISTING CONDITIONS



EXISTING CROSSWALK

New crosswalk for senior center crossing



PAINTED CROSSWALK LINES

PROPOSED SOLUTIONS

Enforce No Semi trucks to pass through town they destroy our streets



COLORLED CROSSWALK



RAISED CROSSWALK

Midblock raised crosswalk for school between Benito & Magdalena



EXISTING PARKING



NO PARKING - ENHANCED LANDSCAPE



ON STREET PARKING



ENHANCED ON STREET PARKING

PROPOSED IMAGERY  
LS 1.3



JACOBS

# Town of Guadalupe

Avenida Del Yaqui Bicycle and Pedestrian Improvement Project

EXISTING CONDITIONS



EXISTING SEATING

PROPOSED SOLUTIONS



SINGLE SEAT CHAIRS



*If Concrete Bench  
Light/White color for  
Cool to touch!*

CONCRETE BENCH



GABION SEAT WALL



NO EXISTING BIKE PARKING FACILITIES



WAVE BIKE RACK



*More secure  
for a bike  
Hard to take  
pieces of bike*

ENHANCED BIKE RACK



ENHANCED BIKE RACK

*Garbage  
Cans*

PROPOSED IMAGERY  
LS 1.4



JACOBS



# Town of Guadalupe

Avenida Del Yaqui Bicycle and Pedestrian Improvement Project

EXISTING CONDITIONS



EXISTING LIGHTING

on the new street lights  
Can electrical outlets  
be added on the upper  
section for future  
light dimmer for the  
holidays?

PROPOSED SOLUTIONS



ENHANCED LIGHTING



3000K AMBER LIGHTING



ENHANCED LIGHTING



4000K WHITE LIGHTING



ENHANCED LIGHTING

Solar panels

PROPOSED IMAGERY  
LS 1.5



JACOBS

Boosters  
Brighter signs  
Color - add more -  
Brighter as our  
Community  
Banner Hangars  
on Light Poles

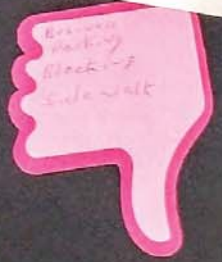

Community  
Bulletin  
Boards

Better  
Bus pull-out  
@ intersection of  
A.V/Goad Rd +  
A.V/cambs

2000 minimum K/L  
Flag on bus stop vs  
4:17 4:50 PM

Flashing  
pedestrian  
walk  
Signs from  
Town Hall

SAFELY  
SCHOOL  
CROSSING

Good Bright  
Lighting on  
Crosswalks





<b>Reply</b>	Improved visuals are now available for review on Town of Guadalupe website at <a href="http://www.guadalupeaz.org">www.guadalupeaz.org</a> under Community News	Improved visuals are now available for review on Town of Guadalupe website at <a href="http://www.guadalupeaz.org">www.guadalupeaz.org</a> under Community News	Improved visuals are now available for review on Town of Guadalupe website at <a href="http://www.guadalupeaz.org">www.guadalupeaz.org</a> under Community News	Improved visuals are now available for review on Town of Guadalupe website at <a href="http://www.guadalupeaz.org">www.guadalupeaz.org</a> under Community News	Improved visuals are now available for review on Town of Guadalupe website at <a href="http://www.guadalupeaz.org">www.guadalupeaz.org</a> under Community News	Improved visuals are now available for review on Town of Guadalupe website at <a href="http://www.guadalupeaz.org">www.guadalupeaz.org</a> under Community News	Improved visuals are now available for review on Town of Guadalupe website at <a href="http://www.guadalupeaz.org">www.guadalupeaz.org</a> under Community News	Improved visuals are now available for review on Town of Guadalupe website at <a href="http://www.guadalupeaz.org">www.guadalupeaz.org</a> under Community News	Improved visuals are now available for review on Town of Guadalupe website at <a href="http://www.guadalupeaz.org">www.guadalupeaz.org</a> under Community News
--------------	---	---	---	---	---	---	---	---	---

<b>Survey Comm</b> 6/17/2020 15:13	Skipped	Skipped	Skipped	Skipped	Skipped	Skipped	Skipped	Skipped	I am the owner of the building at 8011 s Avenida Del Yaqui, it looks like the new side walk is running thru my Gabion architectural feature. Are you going to relocate it? I also have a paver parking lot I am assuming that you will be putting everything back to look nice? There is a fence and a post on my north lot line, is that going to be replaced? I already have problems with people walking in front of by door instead of using the sidewalk.
------------------------------------	---------	---------	---------	---------	---------	---------	---------	---------	--

<b>Reply</b>									Design team will meet on site with property owner to work through acceptable solutions.
--------------	--	--	--	--	--	--	--	--	---

<b>Survey Comm</b> 6/17/2020 16:14	I do not think the money is well spent as the Town did a improvement project along the canal between Tempe and Guadalupe and its current state is inoperable. Every light along the path has been destroyed. The pedestrian path is VERY DANGEROUS, especially at night. I would like accountability for all funds	Same as previous comment	Same as previous comment	Skipped	Skipped	Skipped	Skipped	Skipped	Skipped
------------------------------------	--	--------------------------	--------------------------	---------	---------	---------	---------	---------	---------

**Reply**  
 The Canal project was completed in 2016 and since then the lighting fixture are routinely vandalized. Redesign of the lighting is planned. The canal project is a separate project from the Avenida del Yaqui pedestrian improvement project. The Avenida del Yaqui project is a \$3.5M federally-funded project.

**Survey Comm** 6/18/2020 14:29 Please allow this project to go through. There are many avid bike riders that would enjoy this. It also allows for  
 Skipped Skipped Skipped Skipped Skipped Skipped Skipped

**Reply**  
 Thank you. Construction is anticipated to begin in October 2021

**Survey Comm** 6/18/2020 15:32 Thank you for adding a bike lane that is independent of the parking spaces  
 Looks great Looks good Skipped Skipped Skipped Skipped Skipped

**Reply**  
 You're welcome

**Survey Comm** 6/19/2020  
 General comment - dimensions are illegible and even when I zoom in can't be seen. Also, if I copy the image and zoom in to see design details they become blurry. I can't read the LEGEND clearly or tell for sure what the proposed speed limit is or what other signs depict. The flyer I received in the mail was too small to tell these details as well. As far as feedback on the design: 1) A typical section would help to confirm, but is that parking on the west side of the road? If it's parking, does it get used enough to warrant this? Was parking protection of the bike lane considered? Is bike lane wide enough to avoid door zone of cars getting out of parking if that is parking? 2) Is the proposed speed limit 25? It's hard to tell. 3) I can't read what the yellow dots are. Are those street lights? Was lighting reviewed to ensure no  
 Do turn movements on Calle Guadalupe warrant dedicated turn lanes? Can space be repurposed to maintain an east west bike lane? This is a high bike usage corridor. Same comments as before about parking. With the green paint - does town staff have the ability to maintain? Would a wide gutter pan at bike lane width be a better long term solution? Will there be signage at NB merge area between NB RTL and bike lane to alert motorists to yield to cyclists?  
 Will there be signage for yielding to bicycles for SB rtl crossing the bike lane?  
 What kind of treatment is going with crosswalk at Calle Encinas? A crosswalk alone is not sufficient but it's hard to tell what the signage is.  
 Is Calle Iglesias current all way stop control? Is it warranted? will any signage enhancement accompany the Calle San Angelo crosswalks?  
 Is Calle Iglesias current all way stop control? Is it warranted? will any signage enhancement accompany the Calle San Angelo crosswalks?  
 Does the pavement marking indicate that Calle Gloria crosswalk is raised? Any signing to accompany this crosswalk?  
 Please work with Tempe to make bike lane continuous. Suggest wayfinding at Highline canal crossing. why not make crosswalk at highline canal have a refuge island? Suggest including island on both sides of crosswalk. Is Calle Cerritos currently stop controlled? Is it warranted? Can't tell what speed limit signs say but suggest having a speed reduction signage entering Town of Guadalupe from City of Tempe. General comment - was shading considered? This is a harsh pedestrian environment without any shading. If not along the entire corridor maybe at least at intersections where pedestrians may wait and the shade can be a great refuge. Also, suggest utilizing raised median at highline canal as a Town Gateway. This is an

## Reply

Thank you for the comments. Better drawings are available on the Town of Guadalupe website. In reply: 1) Generally, yes by adjacent property owners. 2) Present speed limit is 25 mph and it will remain 25 mph. 3) Yes and Yes. 4) New sidewalk width will vary from 6 foot to 8 foot. 5) Purple rectangles depict bus shelters which are the existing custom Town of Guadalupe shelters with trash bins. The current design does not include adding any specific new lighting or bike parking at the existing bus shelter locations.

Performing revisions to traffic movements and adding bike lanes on East/West Calle Guadalupe is outside of the Scope of Work for this project (Avenida del Yaqui Pedestrian Improvements). Town maintenance staff will maintain the green paint for the bike lanes approaching intersections. A wide concrete gutter pan was considered for use as the bike lanes for the project but the cost of using the 6' side concrete gutters was deemed unfeasible for the project due to budget constraints. Yes there will be signage at NB merge areas to alert motorists to yield to cyclists.

Yes there,will there be signage for motorists to yield to cyclists where the SB RTL crosses the bike lane.

A striped crosswalk is planned along the south leg of the intersection of Calle Encinas and Avenida del Yaqui along with installation of "Pedestrian Crosswalk" signs in both directions.

Yes the Calle Iglesias intersection is currently an all way stop controlled intersection. Regarding warrant of stop conditions, the project is matching the existing stop sign conditions of the project. Currently there are no new "Pedestrian Crossing" signs identified at the Calle San Angelo crosswalks.

See previous response.

Yes the pavement marking at Calle Gloria crosswalk indicate that this will be a raised crosswalk across Avenida del Yaqui. There will be new "Pedestrian Crosswalk" signs placed in both directions in advance of the crosswalk to provide advance warning of the crossing.

We are working with the City of Tempe on this project but the limits of improvements that can be provided with this project must remain within the Town of Guadalupe limits which restrict including some of the suggested items above regarding additional striping to the north, additional median island and signage. The project is attempting to provide as much shade as possible but this is restricted by the limitations of space between back of new sidewalks (intent of the project) and Right of Way. In addition no new trees can be planted along the west side under the SRP power lines due to SRP restrictions.

ADOT File No.: IGA 19-0007278-I  
Amendment No. One: 20-0008068-I  
AG Contract No.: P001 2019 001146  
Project Location/Name: Avenida Del Yaqui; Baseline Rd – Calle Carmen  
Type of Work: Pedestrian and Bike Lane Improvements  
Federal-aid No.: GUA-0(205)T  
ADOT Project No.: T0212 01D/03D/01C  
TIP/STIP No.: GDL21-803C/  
GDL21-805C/GDL19-805D  
CFDA No.: 20.205 - Highway Planning and Construction  
Budget Source Item No.: N/A

C2019-12A  
**AMENDMENT NO. ONE**  
**TO**  
**INTERGOVERNMENTAL AGREEMENT**

BETWEEN  
THE STATE OF ARIZONA  
AND  
THE TOWN OF GUADALUPE

**THIS AMENDMENT NO. ONE to INTERGOVERNMENTAL AGREEMENT (the “Amendment No. One”)**, is entered into this date \_\_\_\_\_, pursuant to Arizona Revised Statutes (“A.R.S.”) §§ 11-951 through 11-954, as amended, between the STATE OF ARIZONA, acting by and through its DEPARTMENT OF TRANSPORTATION (the “State” or “ADOT”) and the TOWN OF GUADALUPE, acting by and through its MAYOR and TOWN COUNCIL (the “Town”). The State and the Town are collectively referred to as the “Parties.”

**WHEREAS**, the INTERGOVERNMENTAL AGREEMENT, IGA 19-0007278-I, A.G. Contract No. P001 2019 001146, was executed on June 4, 2019 (the “Original Agreement”);

**WHEREAS**, the State is empowered by A.R.S. § 28-401 to enter into this Amendment No. One and has delegated to the undersigned the authority to execute this Amendment No. One on behalf of the State;

**WHEREAS**, the Town is empowered by A.R.S. § 9-240 to enter into this Amendment No. One and has by resolution, a copy of which is attached and made a part of, resolved to enter into this Amendment No. One and has authorized the undersigned to execute this Amendment No. One on behalf of the Town; and

**NOW THEREFORE, in consideration of the mutual terms expressed herein, the purpose of this Amendment No. One is to revise Project costs; Exhibit A is revised and replaced accordingly. The Parties desire to amend the Original Agreement, as follows:**

**Consistent with the Original Agreement, the Town has been invoiced and paid \$32,205.00 and will pay the remaining \$1,995.00 for the Town’s share of Project Development Administration (PDA) and design costs within 30 days of receipt of an invoice.**



**I. RECITALS****(NO CHANGES)****II. SCOPE OF WORK****Section II, Paragraph 2.e. is revised, as follows:**

2. The State will:
  - e. After completion of design and prior to bid advertisement, invoice the Town for the actual PDA costs, as applicable, and the Town's share of the Project construction costs, estimated at \$285,087.00. After the Project costs for construction are finalized, the State will either invoice or reimburse the Town for the difference between estimated and actual costs. De-obligate or otherwise release any remaining federal funds from the design phase of the Project.

**Section II, Paragraph 3.d. is revised, as follows:**

3. The Town will:
  - d. After completion of design, within 30 days of receipt of an invoice from the State and prior to bid advertisement, pay to the State, any outstanding PDA costs and the Town's share of the Project construction costs, estimated at \$285,087.00. Be responsible for and pay the difference between the estimated and actual construction costs of the Project, within 30 days of receipt of an invoice.

**III. MISCELLANEOUS PROVISIONS****Section III, Paragraph 20. is revised, as follows:**

20. The Parties shall ensure that all contractors comply with the applicable requirements of A.R.S. §35-393.01.

**EXCEPT AS AMENDED, ALL OTHER** terms and conditions of the Original remain in full force and effect.

---

**THIS AMENDMENT NO. One** shall become effective upon signing and dating of the Determination Letter by the State's Attorney General.

**IN ACCORDANCE WITH** A.R.S. § 11-952 (D) attached and incorporated in this Amendment No. One is the written determination of each Party's legal counsel that the Parties are authorized under the

laws of this State to enter into this Amendment No. One and that the Amendment No. One is in proper form.

**IN WITNESS WHEREOF**, the Parties have executed this Amendment No. One the day and year first above written.

**TOWN OF GUADALUPE**

**STATE OF ARIZONA**  
Department of Transportation

By \_\_\_\_\_  
**VALERIE MOLINA**  
Mayor

By \_\_\_\_\_  
**STEVE BOSCHEN, PE**  
Division Director

ATTEST:

By \_\_\_\_\_  
**JEFF KULAGA**  
Town Clerk

**ATTORNEY APPROVAL FORM FOR THE TOWN OF GUADALUPE**

I have reviewed the above referenced Amendment No. One to the Original Agreement between the State of Arizona, acting by and through its DEPARTMENT OF TRANSPORTATION, and the TOWN OF GUADALUPE, an agreement among public agencies which, has been reviewed pursuant to Arizona Revised Statutes §§ 11-951 through 11-954 and declare this Amendment No. One to be in proper form and within the powers and authority granted to the Town under the laws of the State of Arizona.

No opinion is expressed as to the authority of the State to enter into this Amendment No. One.

\_\_\_\_\_  
Town Attorney

\_\_\_\_\_  
Date

# EXHIBIT A

## IGA 19-0007278-I Amendment No. One: 20-0008068-I Cost Estimate

### T0212 01D/03D/01C

The federal funds will be used for the ADOT Project Development Administration (PDA), scoping/design, and construction of the Project, including the construction engineering (CE) and administration cost. The estimated Project costs are as follows:

#### **PDA/ Scoping/Design:**

Federal-aid funds @ 94.3%	\$ 565,800.00
Town's match @ 5.7%	\$ 34,200.00
<b>Subtotal - PDA/Scoping/Design</b>	<b>\$ 600,000.00</b>

#### **Construction:**

Federal-aid funds @ 94.3%	\$ 4,716,433.00
Town's match @ 5.7%	\$ 285,087.00
<b>Subtotal - Construction*</b>	<b>\$ 5,001,520.00</b>

<b>Estimated TOTAL Project Cost</b>	<b>\$ 5,601,520.00</b>
-------------------------------------	------------------------

<b>Total Federal Funds</b>	<b>\$ 5,282,233.00</b>
----------------------------	------------------------

<b>Total Estimated Town Funds</b>	<b>\$ 319,287.00</b>
-----------------------------------	----------------------

\* (Includes 15% CE (this percentage is subject to change, any change will require concurrence from the Town) and 5% Project contingencies)

ADOT CAR No.: IGA 19-0007278-I  
 AG Contract No.: P001 2019 001146  
 Project Location/Name: Avenida Del Yaqui; Baseline Rd – Calle Carmen  
 Type of Work: Pedestrian and Bike Lane Improvements  
 Federal-aid No.: GUA-0(205)T  
 ADOT Project No.: T0212 03D/01C  
 TIP/STIP No.: GDL21-803C/  
 GDL21-805C/GDL19-805D  
 CFDA No.: 20.205 - Highway Planning and Construction  
 Budget Source Item No.: NA

**INTERGOVERNMENTAL AGREEMENT**

BETWEEN  
 THE STATE OF ARIZONA  
 AND  
 THE TOWN OF GUADALUPE

**THIS AGREEMENT** is entered into this date June 4, 2019, pursuant to the Arizona Revised Statutes (“A.R.S.”) §§ 11-951 through 11-954, as amended, between the STATE OF ARIZONA, acting by and through its DEPARTMENT OF TRANSPORTATION (the “State” or “ADOT”) and the TOWN OF GUADALUPE, acting by and through its Mayor and Town Council (the “Town”). The State and the Town are collectively referred to as “Parties.”

**I. RECITALS**

1. The State is empowered by A.R.S. § 28-401 to enter into this Agreement and has delegated to the undersigned the authority to execute this Agreement on behalf of the State.
2. The Town is empowered by A.R.S. § 9-240 to enter into this Agreement and has by resolution, a copy of which is attached and made a part of, resolved to enter into this Agreement and has authorized the undersigned to execute this Agreement on behalf of the Town.
3. The improvements proposed in this Agreement, include the design and construction of sidewalk and bike lane on Avenida del Yaqui, northbound and southbound, between Highland Canal and Calle Carmen, (the “Project”). The Project includes mill and overlay of the full roadway cross section of existing asphaltic concrete pavement and complete reconstruction of the concrete curb, gutter and sidewalk along both sides of the corridor. The corridor improvement will also include new pavement markings and added bicycle facilities. Enhanced pedestrian crossings and amenities, traffic calming features and Safe Routes to School improvements will be installed. The Project includes removal and replacement of all existing traffic control signs along the length of the Project boundary. The State will administer the design and advertise, bid and award the construction phase of the Project.

IGA 19-0007278-I

4. The interest of the State in this Project is the acquisition of federal funds for the use and benefit of the Town and authorization of such federal funds for the Project pursuant to federal law and regulations. The State shall be the designated agent for the Town for the Project, if the Project is approved by Federal Highway Administration (FHWA) and funds for the Project are available.

**THEREFORE**, in consideration of the mutual terms expressed in this Agreement, it is agreed as follows:

---

---

## **II. SCOPE OF WORK**

1. The Parties agree:
  - a. The Project will be performed, completed, accepted and paid for in accordance with the requirements of the Project plans and specifications.
  - b. The final Project amount may exceed the initial estimate(s) identified in Exhibit A, and in such case, the Town is responsible for, and agrees to pay, any and all actual costs exceeding the initial estimate. If the final bid amount is less than the initial estimate, the difference between the final bid amount and the initial estimate will be de-obligated or otherwise released from the Project. The Town acknowledges it remains responsible for, and agrees to pay according to the terms of this Agreement, any and all actual costs exceeding the final bid amount.
  - c. The Town and ADOT will each separately file a Notice of Intent (NOI) under the Construction General Permit (CGP) with the Arizona Department of Environmental Quality (ADEQ) before construction begins, if applicable to the Project.
2. The State will:
  - a. Execute this Agreement, and if the Project is approved by FHWA and funds for the Project are available, be the Town's designated agent for the Project.
  - b. After this Agreement is executed, and prior to performing or authorizing any work, invoice the Town for the initial Project Development Administration (PDA) costs and the Town's share of the Project design costs, estimated at \$32,205.00. If PDA costs exceed the estimate during the development of design, notify the Town, obtain concurrence prior to continuing with the development of design, and invoice as determined by ADOT and the Town for additional costs to complete PDA for the Project. After the Project costs are finalized invoice or reimburse the Town for the difference between actual costs and the amount the Town has already paid for PDA.
  - c. After receipt of the PDA costs and the Town's estimated share of the Project design costs, on behalf of the Town, prepare and provide all documents pertaining to the design and post-design of the Project, incorporating comments from the Town, as appropriate. Review and approve documents required by FHWA to qualify the Project for and to receive federal funds. Perform tasks that may consist of, but are not limited

IGA 19-0007278-I

- to, preparation of environmental documents; analysis and documentation of environmental categorical exclusion determinations; geologic materials testing and analysis; right-of-way related activities; preparation of reports, design plans, maps, specifications and cost estimates and other related tasks essential to the development of the Project.
- d. Submit all required documentation pertaining to the Project to FHWA with the recommendation that the maximum federal funds programmed for this Project be approved for design. After receipt of FHWA authorization, proceed to advertise for and enter into contract(s) with the consultant(s) for the design and post design of the Project. Should costs exceed the maximum federal funds available it is understood and agreed that the Town will be responsible for any overage.
  - e. After completion of design and prior to bid advertisement, invoice the Town for the actual PDA costs, as applicable, and the Town's share of the Project construction costs, estimated at \$169,216.00. After the Project costs for construction are finalized, the State will either invoice or reimburse the Town for the difference between estimated and actual costs. De-obligate or otherwise release any remaining federal funds from the design phase of the Project.
  - f. After receipt of the actual PDA costs, if applicable, and the Town's estimated share of the Project construction costs, submit all required documentation to FHWA with the recommendation that the maximum federal funds programmed for construction of this Project be approved. Should costs exceed the maximum federal funds available, it is understood and agreed that the Town will be responsible for any overage.
  - g. After receipt of FHWA authorization, proceed to advertise for, receive and open bids award and enter into a contract with the firm for the construction of the Project. If the bid amounts exceed the construction cost estimate, obtain Town concurrence prior to awarding the contract. After the Project is awarded, invoice the Town for the difference between estimated and actual costs, if applicable.
  - h. Notify the Town of substantial completion and final acceptance of the Project. At such time, file a Notice of Termination (NOT) with ADEQ transferring CGP responsibilities to the Town, and provide a copy to the Town indicating that the State's maintenance responsibility of the Project is terminated, as applicable.
  - i. Notify the Town of substantial completion and final acceptance of the Project; coordinate with the Town and turn over full responsibility of the Project improvements.
  - j. Not be obligated to maintain the Project, should the Town fail to budget or provide for proper and perpetual maintenance as set forth in this Agreement.
3. The Town will:
- a. Designate the State as the Town's authorized agent for the Project.
  - b. Within 30 days of receipt of an invoice from the State, pay the initial PDA costs and the Town's share of Project design costs, estimated at \$32,205.00. Agree to be responsible

IGA 19-0007278-I

for actual PDA costs, if during the development of design, PDA costs exceed the initial estimate. Be responsible and pay for the difference between the estimated and actual PDA and design costs of the Project within 30 days of receipt of an invoice.

- c. Review design plans, specifications, cost estimates and other such documents required for the construction bidding and construction of the Project, including design plans and documents required by FHWA to qualify projects for and to receive federal funds; provide design review comments to the State as appropriate.
- d. After completion of design, within 30 days of receipt of an invoice from the State and prior to bid advertisement, pay to the State, any outstanding PDA costs and the Town's share of the Project construction costs, estimated at \$169,216.00. Be responsible for and pay the difference between the estimated and actual construction costs of the Project, within 30 days of receipt of an invoice.
- e. Be responsible for all costs incurred in performing and accomplishing the work as set forth under this Agreement, that are not covered by federal funding. Should costs be deemed ineligible or exceed the maximum federal funds available, it is understood and agreed that the Town is responsible for these costs; payment for these costs shall be made within 30 days of receipt of an invoice from the State.
- f. Certify that all necessary rights-of-way have been or will be acquired prior to advertisement for bid and also certify that all obstructions or unauthorized encroachments of whatever nature, either above or below the surface of the Project area, shall be removed from the proposed right-of-way, or will be removed prior to the start of construction, in accordance with The Uniform Relocation Assistance and Real Property Acquisition Policies Act of 1970 as amended; 49 CFR 24.102 Basic Acquisition Policies; 49 CFR 24.4 Assurances, Monitoring and Corrective Action, parts (a) & (b) and ADOT Right of Way Procedures Manual: 8.02 Responsibilities, 8.03 Prime Functions, 9.06 Monitoring Process and 9.07 Certification of Compliance. Coordinate with the appropriate State's Right-of-Way personnel during any right-of-way process performed by the Town, if applicable.
- g. Certify that the Town has adequate resources to discharge the Town's real property related responsibilities and ensures that its Title 23-funded projects are carried out using the FHWA approved and certified ADOT Right of Way Procedures Manual and that they will comply with current FHWA requirements whether or not the requirements are included in the FHWA approved ADOT Right of Way Procedures Manual. (23 CFR 710.201)
- h. Not permit or allow any encroachments on or private use of the right-of-way, except those authorized by permit. In the event of any unauthorized encroachment or improper use, the Town shall take all necessary steps to remove or prevent any such encroachment or use.
- i. Automatically grant to the State, by execution of this Agreement, its agents and/or contractors, without cost, the temporary right to enter Town rights-of-way, as required, to conduct any and all construction and preconstruction related activities for the



IGA 19-0007278-I

Project, on, to and over said Town rights-of-way. This temporary right will expire with completion of the Project.

- j. Investigate and document utilities within the Project limits; submit findings to ADOT determining prior rights or no prior rights; approve an easement within the final right-of-way to re-establish the prior right location for those utilities with prior rights.
- k. Be obligated to incur any expenditure should unforeseen conditions or circumstances increase Project costs. Be responsible for the cost of any Town requested changes to the scope of work of the Project, such changes will require State and FHWA approval. Be responsible for any contractor claims for additional compensation caused by Project delay attributable to the Town. Payment for these costs will be made to the State within 30 days of receipt of an invoice from the State.
- l. After notification of final acceptance by the State, assume and maintain full responsibility of the Project, including Storm Water Pollution Prevention Plans (SWPPP) inspections, maintenance, and required documentation, until final stabilization is reached. Provide the NOI number to the State and the Contractor, accept CGP responsibilities at time of transfer, and file an NOT with ADEQ when final stabilization is reached, as applicable.
- m. After completion and final acceptance of the Project, agree to maintain and assume full responsibility of the Project and all Project components.
- n. Pursuant to 23 USC 102(b), repay all federal funds reimbursements for preliminary engineering costs on the Project if it does not advance to right of way acquisition or construction within 10 years after federal funds were first made available.

### **III. MISCELLANEOUS PROVISIONS**

- 1. This Agreement shall become effective upon signing and dating of the Determination Letter by the State's Attorney General.
- 2. Any change or modification to the Project will only occur with the mutual written consent of both Parties.
- 3. The terms, conditions and provisions of this Agreement shall remain in full force and effect until completion of the Project and all related deposits and/or reimbursements are made. Any provisions for maintenance shall be perpetual, unless assumed by another competent entity.
- 4. This Agreement may be cancelled at any time prior to the award of the Project contract and after 30 days written notice to the other Party. It is understood and agreed that, in the event the Town terminates this Agreement, the Town shall be responsible for all costs incurred by the State up to the time of termination. It is further understood and agreed that in the event the Town terminates this Agreement, the State shall in no way be obligated to complete or maintain the Project.

IGA 19-0007278-I

5. The Town shall indemnify, defend, and hold harmless the State, any of its departments, agencies, officers or employees (collectively referred to in this paragraph as the "State") from any and all claims, demands, suits, actions, proceedings, loss, cost and damages of every kind and description, including reasonable attorneys' fees and/or litigation expenses (collectively referred to in this paragraph as the "Claims"), which may be brought or made against or incurred by the State on account of loss of or damage to any property or for injuries to or death of any person, to the extent caused by, arising out of, or contributed to, by reasons of any alleged act, omission, professional error, fault, mistake, or negligence of the Town, its employees, officers, directors, agents, representatives, or contractors, their employees, agents, or representatives in connection with or incident to the performance of this Agreement. The Town's obligations under this paragraph shall not extend to any Claims to the extent caused by the negligence of the State, except the obligation does apply to any negligence of the Town which may be legally imputed to the State by virtue of the State's ownership or possession of land. The Town's obligations under this paragraph shall survive the termination of this Agreement.
6. The State shall include Section 107.13 of the 2008 version of the Arizona Department of Transportation Standard Specifications for Road and Bridge Construction, incorporated into this Agreement by reference, in the State's contract with any and all contractors, of which the Town shall be specifically named as a third-party beneficiary. This provision may not be amended without the approval of the Town.
7. The cost of design, construction and construction engineering work under this Agreement is to be covered by the federal funds programmed for this Project, up to the maximum available. The Town acknowledges that actual Project costs may exceed the maximum available amount of federal funds, or that certain costs may not be accepted by FHWA as eligible for federal funds. Therefore, the Town agrees to pay the difference between actual costs of the Project and the federal funds received.
8. Should the federal funding related to this Project be terminated or reduced by the federal government, or Congress rescinds, fails to renew, or otherwise reduces apportionments or obligation authority, the State shall in no way be obligated for funding or liable for any past, current or future expenses under this Agreement.
9. The cost of the Project under this Agreement includes indirect costs approved by FHWA, as applicable.
10. The Parties warrant compliance with the Federal Funding Accountability and Transparency Act of 2006 and associated 2008 Amendments (the "Act"). Additionally, in a timely manner, the Town will provide information that is requested by the State to enable the State to comply with the requirements of the Act, as may be applicable.
11. The Town acknowledges and will comply with Title VI of the Civil Rights Act Of 1964.
12. The Town acknowledges compliance with federal laws and regulations and may be subject to the CODE OF FEDERAL REGULATIONS, TITLE 2, PART 200 (also known as The Uniform Grant Guidance). Entities that expend \$750,000.00 or more (on or after 12/26/14) of federal assistance (federal funds, federal grants, or federal awards) are required to comply by having an independent audit in accordance with §200.331 Subpart F. Either an electronic

IGA 19-0007278-I

or hardcopy of the Single Audit is to be sent to Arizona Department of Transportation Financial Management Services within the required deadline of nine months of the sub recipient fiscal year end.

ADOT – FMS  
Attn: Cost Accounting Administrator  
206 S 17<sup>th</sup> Ave. Mail Drop 204B  
Phoenix, AZ 85007  
[SingleAudit@azdot.gov](mailto:SingleAudit@azdot.gov)

13. This Agreement shall be governed by and construed in accordance with Arizona laws.
14. This Agreement may be cancelled in accordance with A.R.S. § 38-511.
15. The Town shall retain all books, accounts, reports, files and other records relating to the Agreement for five years after completion of the Project. These documents shall be subject at all reasonable times to inspection and audit by the State. Such records shall be produced by the Town at the request of ADOT.
16. This Agreement is subject to all applicable provisions of the Americans with Disabilities Act (Public Law 101-336, 42 U.S.C. 12101-12213) and all applicable federal regulations under the Act, including 28 CFR Parts 35 and 36. The Parties to this Agreement shall comply with Executive Order Number 2009-09 issued by the Governor of the State of Arizona and incorporated in this Agreement by reference regarding “Non-Discrimination.”
17. Non-Availability of Funds: Every obligation of the State under this Agreement is conditioned upon the availability of funds appropriated or allocated for the fulfillment of such obligations. If funds are not allocated and available for the continuance of this Agreement, this Agreement may be terminated by the State at the end of the period for which the funds are available. No liability shall accrue to the State in the event this provision is exercised, and the State shall not be obligated or liable for any future payments as a result of termination under this paragraph.
18. In the event of any controversy, which may arise out of this Agreement, the Parties agree to abide by arbitration as is set forth for public works contracts if required by A.R.S. § 12-1518.
19. The Parties shall comply with the applicable requirements of A.R.S. § 41-4401.
20. The Parties shall certify that all contractors comply with the applicable requirements of A.R.S. §35-393.01. <sup>1</sup>
21. The Parties shall comply with all applicable laws, rules, regulations and ordinances, as may be amended.

---

<sup>1</sup> In *Jordahl v. Brnovich et al.*, Case No. 3:17-cv-08263 (D. Ariz.), the U.S. District Court entered a preliminary injunction that enjoins the State from enforcing A.R.S. § 35-393.01(A) (the “Anti-Israel Boycott Provision”). That statute states that: “[a] public entity may not enter into a contract with a company to acquire or dispose of services, supplies, information technology or construction unless the contract includes a written certification that the company is not currently engaged in, and agrees for the duration of the contract to not engage in, a boycott of Israel.” Unless and until the District Court’s injunction in *Jordahl* is stayed or lifted, the Anti-Israel Boycott Provision (A.R.S. § 35-393.01(A)) is unenforceable and the State will take no action to enforce it.

IGA 19-0007278-I

22. All notices or demands upon any Party to this Agreement shall be in writing and shall be delivered in person or sent by mail, addressed as follows:

**For Agreement Administration:**

Arizona Department of Transportation  
Joint Project Agreement Section  
205 S. 17<sup>th</sup> Avenue, Mail Drop 637E  
Phoenix, AZ 85007  
[JPABranch@azdot.gov](mailto:JPABranch@azdot.gov)

Town of Guadalupe  
Attn: Jeff Kulaga  
9241 S. Avenida del Yaqui  
Guadalupe, AZ 85283  
480.505.5376  
[JKulaga@guadalupeaz.org](mailto:JKulaga@guadalupeaz.org)

**For Project Administration:**

Arizona Department of Transportation  
Project Management Group  
205 S. 17<sup>th</sup> Avenue, Mail Drop 614E  
Phoenix, AZ 85007  
602.712.7545

Town of Guadalupe  
Attn: Jeff Kulaga  
9241 S. Avenida del Yaqui  
Guadalupe, AZ 85283  
480.505.5376  
[JKulaga@guadalupeaz.org](mailto:JKulaga@guadalupeaz.org)

**For Financial Administration:**

Arizona Department of Transportation  
Project Management Group  
205 S. 17<sup>th</sup> Avenue, Mail Drop 614E  
Phoenix, AZ 85007  
602.712.7545

Town of Guadalupe  
Attn: Robert Thaxton  
9241 S. Avenida del Yaqui  
Guadalupe, AZ 85283  
480.505.5374  
[RThaxton@guadalupeaz.org](mailto:RThaxton@guadalupeaz.org)

23. In accordance with A.R.S. § 11-952 (D), attached and incorporated in this Agreement is the written determination of each Party's legal counsel that the Parties are authorized under the laws of this State to enter into this Agreement and that the Agreement is in proper form.

---

**IN WITNESS WHEREOF**, the Parties have executed this Agreement the day and year first above written.

**TOWN OF GUADALUPE**

**STATE OF ARIZONA**

Department of Transportation

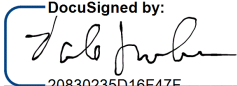
DocuSigned by:  
  
By \_\_\_\_\_  
20830236016F47E...  
**VALERIE MOLINA**  
Mayor

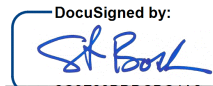
DocuSigned by:  
  
By \_\_\_\_\_  
2C8F28BDDC8C4A2...  
**STEVE BOSCHEN, PE**  
Division Director

ATTEST:

DocuSigned by:  
  
By \_\_\_\_\_  
673D05923288483...  
**JEFF KULAGA**  
Town Clerk

**IGA 19-0007278-I**

**ATTORNEY APPROVAL FORM FOR THE TOWN OF GUADALUPE**

I have reviewed the above referenced Intergovernmental Agreement between the State of Arizona, acting by and through its DEPARTMENT OF TRANSPORTATION, and the TOWN OF GUADALUPE, an agreement among public agencies which, has been reviewed pursuant to Arizona Revised Statutes §§ 11-951 through 11-954 and declare this Agreement to be in proper form and within the powers and authority granted to the Town under the laws of the State of Arizona.

No opinion is expressed as to the authority of the State to enter into this Agreement.

DATED this **31st** \_\_\_\_\_ day of **may** \_\_\_\_\_, 2019.

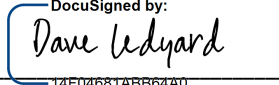
DocuSigned by:  
  
14F04681ABB64A0...  
**DAVE LEDYARD**  
Town Attorney

**EXHIBIT A****IGA 19-0007278-I  
Cost Estimate****T0212 03D/01C**

The federal funds will be used for the scoping/design and construction of the Project, including the construction engineering (CE) and administration cost. The estimated Project costs are as follows:

**T0212 03D (scoping/design/ADOT Project Development Administration (PDA) Cost):**

Federal-aid funds @ 94.3%	\$ 532,795.00
Town's match @ 5.7%	<u>\$ 32,205.00</u>

<b>Subtotal - Scoping/Design/PDA</b>	<b>\$ 565,000.00</b>
--------------------------------------	----------------------

**T0212 01C (construction):**

Federal-aid funds @ 94.3%	\$ 2,799,499.00
Town's match @ 5.7%	<u>\$ 169,216.00</u>

<b>Subtotal - Construction*</b>	<b>\$ 2,968,715.00</b>
---------------------------------	------------------------

<b>Estimated TOTAL Project Cost</b>	<b>\$ 3,533,715.00</b>
-------------------------------------	------------------------

<b>Total Estimated Town Funds</b>	<b>\$ 201,421.00</b>
<b>Total Federal Funds</b>	<b>\$ 3,332,294.00</b>

\* (Includes 15% CE (this percentage is subject to change, any change will require concurrence from the Town) and 5% Project contingencies)

RESOLUTION NO. R2019.07

A RESOLUTION OF THE TOWN COUNCIL OF THE TOWN OF GUADALUPE (TOWN), ARIZONA, AUTHORIZING THE MAYOR TO SIGN INTERGOVERNMENTAL AGREEMENT 19-0007278-I WITH THE STATE OF ARIZONA (STATE), ACTING BY AND THROUGH ITS DEPARTMENT OF TRANSPORTATION (ADOT) AND THE TOWN OF GUADALUPE, ACTING BY AND THROUGH ITS MAYOR AND TOWN COUNCIL FOR THE DESIGN AND CONSTRUCTION OF SIDEWALK AND BIKE LANE ON AVENIDA DEL YAQUI, NORTHBOUND AND SOUTHBOUND, BETWEEN HIGHLAND CANAL AND CALLE CARMEN.

WHEREAS, The State is empowered by A.R.S. § 28-401 to enter into this Agreement and has delegated to the undersigned the authority to execute this Agreement on behalf of the State; and;

WHEREAS, The Town is empowered by A.R.S. § 9-240 to enter into this Agreement and has by Resolution, a copy of which is attached and made a part of, resolved to enter into this Agreement and has authorized the undersigned to execute this Agreement on behalf of the Town; and;

WHEREAS, The improvements proposed in this Agreement, include the design and construction of sidewalk and bike lane on Avenida del Yaqui, northbound and southbound, between Highland Canal and Calle Carmen, (the "Project"), and includes mill and overlay of the full roadway cross section of existing asphaltic concrete pavement and complete reconstruction of the concrete curb, gutter and sidewalk along both sides of the corridor; and;

WHEREAS, The corridor improvement will also include new pavement markings and added bicycle facilities. Pedestrian crossings and amenities, traffic calming features and Safe Routes to School improvements will be installed. The Project includes removal and replacement of all existing traffic control signs along the length of the Project boundary. The State will administer the design and advertise, bid and award the construction phase of the Project; and;

WHEREAS, The interest of the State in this Project is the acquisition of federal funds for the use and benefit of the Town and authorization of such federal funds for the Project pursuant to federal law and regulations; and;

WHEREAS, The State shall be the designated agent for the Town for the Project, if the Project is approved by Federal Highway Administration (FHWA) and funds for the Project are available; and

WHEREAS, intergovernmental IGA 19-0007278-I (Attachment A) shall become effective upon signed approval of both the Town and State through ADOT; and

NOW THEREFORE, BE IT RESOLVED BY THE TOWN COUNCIL OF THE TOWN OF GUADALUPE, ARIZONA AS FOLLOWS:

The Mayor is authorized and directed to execute all documents in furtherance of this intergovernmental agreement with the state of Arizona (State), acting by and through its department of transportation (ADOT).

PASSED AND ADOPTED BY THE TOWN COUNCIL OF THE TOWN OF GUADALUPE, ARIZONA, this 30<sup>th</sup> day of May, 2019.

  
Valerie Molina, Mayor

ATTEST:

  
Jeff Kulaga, Town Manager / Clerk

APPROVED AS TO FORM:

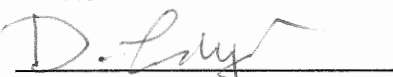
  
David Ledyard, Town Attorney



# Town of Guadalupe Request for Quotes

---

FINANCIAL STATEMENT AUDIT SERVICES

Town of Guadalupe  
9241 S. Avenida del Yaqui  
Guadalupe, AZ 85283



**TOWN OF GUADALUPE  
REQUEST FOR QUOTES  
FOR  
FINANCIAL STATEMENT AUDIT SERVICES**

**Purpose**

The Town of Guadalupe invites all interested firms to submit quotes to provide Professional Auditing Services from qualified firms of certified public accountants, in accordance with the provisions of the Arizona State Statutes and generally accepted government auditing standards (GAGAS), to conduct an examination and to render an opinion on the comprehensive annual financial statements of the Town of Guadalupe, Arizona.

Only those Contractors that are identified through this RFQ process as sufficiently qualified and experienced will be considered to provide the requested services for the Town.

All Request for Quotes responses must be submitted in a PDF format emailed to:

[procurement@guadalupeaz.org](mailto:procurement@guadalupeaz.org)

Attn: Robert Thaxton, Finance Director

**NO LATER THAN 4:00 P.M. MST on April 12, 2021**

All requests for clarification, additional information, or appointments related to this RFQ must be submitted via email on or *before 4 pm on March 22, 2021 to:*

[procurement@guadalupeaz.org](mailto:procurement@guadalupeaz.org)

Attn: Robert Thaxton, Finance Director

**Reservation of Rights**

This RFQ is issued to invite Bidders to submit information and/or bids. Issuance of this RFQ in no way constitutes a commitment by the Town of Guadalupe to select an auditor and/or award a contract. The Town of Guadalupe reserves the right, without prejudice, to reject any or all bids not in compliance with the RFQ specifications and may exercise the right to accept or reject any or all bids submitted. Acceptance of any quote with contractual terms is dependent on the Town's funding.

**I. INTRODUCTION**

The Town of Guadalupe (the Town) is requesting quotes for a three (3) year contract for Financial Statement Audit Services as required by Arizona State Statutes and in conformance with generally accepted government auditing standards (GAGAS). The contract shall commence June 10, 2021 and extend through June 10, 2024 subject to an annual performance evaluation, Town Council budget appropriations, and the needs of the Town. The Town requires the contractor provide auditing services for the fiscal years ending June 30, 2021, 2022, and 2023.

The Town also reserves the right to offer an annual contract extension up to two (2) years also subject to an annual performance evaluation, Town Council budget appropriations, and the needs of the Town.

The first extension (if offered) shall commence June 10, 2024, and extend through June 10, 2025 providing auditing services for the fiscal year ending June 30, 2024. The second and final extension (if offered) shall commence June 10, 2025, and extend through June 10, 2026 providing auditing services for the fiscal year ending June 30, 2025.

## **II. DESCRIPTION OF THE GOVERNMENT**

### **A. General**

The auditor's principal contact with the Town of Guadalupe will be Robert Thaxton, Finance Director or a designated representative, who will coordinate the assistance to be provided by the Town of Guadalupe to the auditor.

### **B. Background Information**

The Town operates under a council-manager form of government. The Town Code of Ordinances governs the operation of the Town of Guadalupe. In addition, certain Town transactions are governed by the State of Arizona General Statutes (CGS). The Town of Guadalupe serves an area of just less than one square mile with a population of approximately 6,500. The Town of Guadalupe's fiscal year begins on July 1 and ends on June 30.

The Town of Guadalupe provides the following services to its citizens:

Fire and Emergency Medical Public Safety; Community Development, Building Inspections, Neighborhood Services; Senior Center and Community Action Program; Parks, Cemetery and Streets and Rights of Way Maintenance; and through contract Police and Public Safety; Animal Control and Library services and programs. The Town of Guadalupe is organized into several departments. All funds are administered by the Finance Department.

More detailed information on the government and its finances can be found in the following documents which are available on the Town of Guadalupe's website at: [www.guadalupeaz.org](http://www.guadalupeaz.org)

1. Annual Financial Statement and Independent Auditor Reports: 2015 through 2020
2. Expenditure Limitation Reports: 2015 through 2020
3. Tentative and Adopted Budgets: 2010-2011 through 2020-21
4. Pension Funding Policy—Arizona Public Safety Personnel Retirement System
5. Guadalupe Cost Policy

### **C. Fund Structure**

The Town of Guadalupe uses all of the funds included in the budget and the Audit Report under general ledger control, and account groups in its financial reporting.

### **D. Budgetary Basis of Accounting**

The Town of Guadalupe prepares its budgets on a basis consistent with generally accepted accounting principles except that encumbrances are recognized as a valid and proper charge against an appropriation in the year the purchase order is issued.

### **E. Pension Plans**

The Town of Guadalupe participates in the following pension plans:

1. All full-time Town employees and some part-time employees participate in the Arizona State Retirement System, with the exception of full-time firefighters.
2. Full-time firefighters participate in the Arizona Public Safety Personnel Retirement System.

### **III. GENERAL REQUIREMENTS**

The Town of Guadalupe is required by State law to provide an annual audit of its financial statement by a Certified Public Accountant in accordance with GAGAS. This requirement includes:

1. A financial statement audit in accordance with generally accepted government auditing standards (GAGAS).
2. A State compliance audit in accordance with the State Compliance Users Guide, issued by the Office of the State Auditor of Arizona.
3. Depending on levels of federal funding, a Single Audit in accordance with the requirements of Title 2 U.S. Code of Federal Regulations Part 200, *Uniform Administrative Requirements, Cost Principles, and Audit Requirements for Federal Awards* (Uniform Guidance). This audit must be submitted to the State Auditor's Office within six months after the end of the year.

To be considered, the proposing independent auditing firm must meet the following minimum criteria:

1. Audit must be performed by a certified public accountant or a public accountant currently licensed by the Arizona State Board of Accountancy.
2. The firm must meet the GAGAS continuing professional education, independence, peer review, and licensing requirements (A.R.S. §9-481).
3. The firm must have experience in governmental auditing. The experience must have been on an entity-wide basis, and an opinion must have been issued.
4. The firm must be able to meet the reporting deadlines described in this Request for Quotes.

### **IV. OBJECTIVE AND SCOPE**

The purpose of this Request for Quotes is to enter into a contract with a certified public accounting firm to provide financial audit services for the fiscal years ending June 30, 2021, June 30, 2022, and June 30, 2023 with extensions to provide financial audit services for the fiscal years ending June 30, 2024, and June 30, 2025. The contract is subject to an annual performance evaluation, Town Council budget appropriations, and the needs of the Town.

The following is the required scope of work the auditor must perform.

#### **A. AUDIT STANDARDS**

The auditor shall perform a financial audit, a State compliance audit, and depending on levels of federal funding, a single audit of the Town of Guadalupe for each fiscal year of the contract period in accordance with the following:

1. Audit standards generally accepted in the United States of America, as promulgated by the American Institute of Certified Public Accountants (AICPA).
2. The AICPA Audits of State and Local Governments audit and accounting guide.
3. Government Auditing Standards, most current revision, published by the U.S. Government Accountability Office.
4. For the single audit, the requirements of Title 2 U.S. Code of Federal Regulations Part 200, *Uniform Administrative Requirements, Cost Principles, and Audit Requirements for Federal Awards*.
5. State of Arizona Uniform Expenditure Reporting System Reporting System requirements (UERS) mandated by the A.R.S. §41-1279.07, with guidelines set forth by the Arizona Auditor General.

## **B. REPORTING REQUIREMENTS**

1. Financial Report — Although the Town has the capability to prepare and print the Town’s Annual Financial Report including all financial statements and combining supplementary information, the Town requests that the auditor prepare and print the Reports. The Town will update the Management Discussion and Analysis (MD&A) and statistical section of the Report and provide timely reviews of the financial statements. The auditor shall audit the records of the Town of Guadalupe and shall issue an auditor’s opinion on the financial statements and in-relation-to opinion on the combining and supplementary information. Such financial statements shall be prepared in conformity with accounting principles generally accepted in the United States of America as promulgated by GASB.
2. Independent Auditor’s Report on Internal Control Over Financial Reporting and on Compliance and Other Matters — The auditor shall issue a report on internal control over financial reporting and on compliance and other matters in accordance with *Government Auditing Standards*.
3. Reports Required for the Title 2 U.S. Code of Federal Regulations Part 200 Audit — If Title 2 U.S. Code of Federal Regulations Part 200 is applicable, the auditor shall prepare all necessary audit reports and schedules as required by Title 2 U.S. Code of Federal Regulations Part 200 *Uniform Administrative Requirements, Cost Principles, and Audit Requirements for Federal Awards*.
4. Report Required for State Compliance Audit — The auditor shall prepare and include a statement expressing positive assurance of compliance with State fiscal laws and other financial issues related to the expenditure of funds received from federal, state or local governments.
5. Management Letter — As appropriate, the auditor shall prepare a comprehensive management letter including the auditor’s findings and recommendations relative to the internal control over financial reporting, compliance with laws and regulations, as applicable, and adherence to generally accepted accounting principles.
6. Reporting Deadlines — The audit must be completed and a physical copy and an electronic copy must be submitted to the Town before the second Thursday in December of each contract year. The firm must be prepared to present the audit report to the Town Council by the second Thursday in December of each contract year.

## **C. AUDIT TERM**

The selected firm shall perform the audit for fiscal year ending June 30, 2021, June 30, 2022, and June 30, 2023 with extensions up to an additional two fiscal years. The contract is subject to an annual performance evaluation, Town Council budget appropriations, and the needs of the Town.

The Town reserves the right to review the contract on a regular basis regarding performance and cost analysis and may negotiate price and service elements during the term of the contract.

## **V. REQUIRED RESPONSE**

The quote must include the following information listed in section V to be considered to perform the audit of the fiscal year ending June 30, 2021. All associated fees must be detailed. Add any level of detail necessary for complete disclosure.

### **A. PROPOSER’S BACKGROUND**

The profile of the proposers should provide general background information. This should include:

1. The organization and size of the proposer, whether it is local, regional, national or international in operations.

2. The location of the office from which the work is to be done and number of professional staff, by staff level, employed at the office. Also describe the proposer's policy on availability/responsiveness of staff and potential fees for questions between audit years.
3. A positive statement that the following mandatory criteria are satisfied:
  - a. An affirmative statement should be included that the firm and all assigned key professional staff are in good standing and properly licensed to practice in the State of Arizona.
  - b. An affirmation that the proposer meets the independence requirements of AICPA Rule 101 and the Government Auditing Standards.
  - c. An affirmation that the firm meets the continuing education and external quality control review requirements contained in the current version of the Government Auditing Standards.
4. Is the proposer, any principals of the proposer, or any affiliate to the proposer the focus of any pending or ongoing litigations, formal investigation, or administrative proceedings related to attestation services? If yes, please describe.
5. A copy of the proposer's most recent peer review report.

#### **B. PROPOSER'S QUALIFICATIONS**

1. Identify the audit partners, audit managers, field supervisors and other staff who will work on the audit, including staff from other than the local office. Include resumes which outline relevant experience and continuing education for the staff auditors up to the individual with final responsibility for the audit.
2. Describe the recent local office auditing experience similar to the type of audit requested.
3. If other auditors are to participate in the audit, those auditors should be required to provide similar information.
4. Provide a list of municipalities to which the audit firm currently provides Financial Statement Auditing Services.
5. An affirmative statement should be included indicating that the firm and all key professional staff are properly qualified to practice in Arizona.

#### **C. APPROACH TO THE EXAMINATION**

Submit a general audit work plan to accomplish the scope defined in these guidelines. The audit work plan should demonstrate the proposer's understanding of the audit requirements and the audit tests and procedures to be applied in completing the audit plan. The plan should detail the expected number of audit hours for the financial audit and compliance audit separately on an annual basis for each fiscal year being audited. The plan should also identify the breakdown of total hours between staff, in-charges, and higher levels. The planned use of specialists, if any, should also be specified. Please base expected number of audit hours on previous experience similar to the type of audit requested.

At times in the past the Town has received sufficient federal funds to trigger a single audit. As such, the proposed is requested to provide a separate estimate for hours and fees for single audit services, should those services be required.

#### **D. TIME REQUIREMENTS**

##### **Proposal Calendar**

The following is a list of key dates up to and including the date quotes are due to be submitted:

Request for quotes issued

March 1, 2021

Questions or clarifications requested by proposer(s)	March 22, 2021, at 4 pm
Due date for proposal	April 12, 2021 at 4 pm
Appointment by Board of Finance	on or before May 10, 2021
Contract date	June 10, 2021

### **Schedule for the Annual Audit and Pension Plan Audit**

Each of the following should be completed by the auditor no later than the dates indicated.

1. Interim work: The auditor shall complete interim fieldwork by October 1.
2. Detailed Audit Plan: The auditor shall provide the Town of Guadalupe by October 1 a detailed audit plan and a list of all schedules to be prepared by the Town of Guadalupe.
3. Fieldwork: The auditor shall complete all fieldwork by October 29.
4. Exit conference and Draft Reports: An exit conference to review draft CAFR and significant audit findings shall be completed by November 12.
5. Draft Comments: The Town of Guadalupe shall provide the auditors with comments on the Draft Report by November 30.
6. Final Report: The auditor shall have final audit report completed by December 15.

If any of these dates fall on a weekend or holiday, the deadline will be moved to the following Monday or the first non-holiday business day.

### **Report Submissions**

Copies of all reports shall be addressed to the Town Council. The successful proposer will also submit copies of reports as required by state and federal audit requirements.

The submission dates for the various reports to the municipality and the appropriate cognizant agencies as follows:

Annual Financial Report	December 15 for the preceding fiscal year
Single Audit Report	December 15 for the preceding fiscal year
ED001 Certification	Original (September 1), Revised (December 31)

The final report should be delivered to:

Town of Guadalupe  
9241 S Avenida del Yaqui  
Guadalupe, AZ 85283

### **E. FEES**

Supply the billing rates, estimated number of billable hours, other billable expenses and a comprehensive “not-to-exceed” fee for the audit, inclusive of travel, per diem, and all other out-of-pocket expenses. It is expected that if the selected certified public accounting firm performs satisfactorily for the June 30, 2021 audit, it will be engaged to perform the audit for up to four additional years. Therefore the “not-to-exceed” fee information requested above should be provided on an annual basis for the fiscal years ending June 30, 2021, June 30, 2022, and June 30, 2023. The Town-option annual contract extensions will be negotiated before the start of each extension. Please provide a separate estimate for hours and fees for single audit services should those services be required.

There is no expressed or implied obligation for the Town of Guadalupe to reimburse firms for any expenses incurred in preparing quotes in response to this request.

**Termination of Contract** – Following implementation, should the Finance Director find that the firm has failed in any material respect to perform its obligations under the agreement; the Town Council may cancel the agreement. The firm shall be liable for damages from such breach including reasonably foreseeable incidental and consequential damages. Should the Town find that the provision of auditing services under the terms of the agreement precludes the Town from administering its duties in an effective and efficient manner; the Town Council may cancel the agreement upon 180 days written notice to the firm. In such event, the Town shall compensate the firm at the pro rata hourly rate for services performed through the effective date of the cancellation which shall be in full and complete satisfaction of the firm's claims. The firm shall promptly return all work papers and work in progress to the Town. The firm shall provide the Town at least 180 days prior written notice of its intent to terminate any agreement.

## **VI. EVALUATION OF QUOTE AND AWARD**

To be considered, the proposal must be received by the Town of Guadalupe, 9241 S. Avenida del Yaqui, Guadalupe, AZ 85283, Attn: Robert Thaxton or [rthaxton@guadalupez.org](mailto:rthaxton@guadalupez.org) by **4:00 pm April 12, 2021**. The Town of Guadalupe reserves the right to reject any or all quotes submitted. Quotes submitted will be evaluated by finance personnel, Town Manager and Town Council members.

During the evaluation process, the selection personnel and the Town of Guadalupe reserve the right, where it may serve the Town of Guadalupe's best interest, to request additional information or clarifications from proposers, or to allow corrections of errors or omissions. At the discretion of the Town of Guadalupe or the selection personnel, firms submitting quotes may be requested to make oral presentations as part of the evaluation process.

Award will be made to the firm submitting the best and most responsive quote in the best interest of the Town of Guadalupe. Award may not be made to the firm submitting the lowest price.

The Town of Guadalupe reserves the right to retain all quotes submitted and to use any ideas in a proposal regardless of whether that proposal is selected. Submission of a proposal indicates acceptance by the firm of the conditions contained in this request for quotes, unless clearly and specifically noted in the proposal submitted and confirmed in the contract between the Town of Guadalupe and the firm selected.

It is anticipated the selection of a firm will be completed no later than May 10, 2021. Following the notification of the selected firm, it is expected that an engagement letter will be executed between both parties within 30 days of approval.

Submission of a proposal indicates acceptance by the firm of the conditions contained in this request for quotes unless clearly and specifically noted in the proposal submitted and confirmed in the contract between the Town of Guadalupe and the firm selected.

The Town of Guadalupe reserves the right without prejudice to reject any or all quotes or parts thereof for any reason, to negotiate changes to proposal terms and to waive minor inconsistencies with the request for proposal.

## **APPENDIX A**

### **INSURANCE REQUIREMENTS—PROFESSIONAL AUDITING SERVICES**

The Auditor (hereinafter called the Contractor) shall procure insurance coverage against claims that may arise from, or in connection with the performance of the work hereunder by the Contractor, his agents, representatives, employees or subcontractors. The Contractor shall keep all the required insurance in force continuously pursuant to their responsibility described in this contract, including any and all extensions. The Contractor shall pay all costs, premiums, and audit charges earned and payable under the required insurance.

For the purpose of this exhibit: the term "Contractor" shall also include their respective agents, representatives, employees or subcontractors; and the term "Town of Guadalupe" (hereinafter called the "Town") shall include their respective officers, agents, officials, employees, volunteers, boards and commissions.

Minimum Scope and Limits of Insurance: The insurance required shall be written for not less than the scope and limits of insurance specified in this exhibit, or required by applicable federal, state and/or municipal law, regulation or requirement, whichever coverage is greater. It is agreed that the scope and limits of insurance coverage specified in this exhibit are minimum requirements and shall in no way limit or exclude the Town from additional limits and coverage provided under the Contractor's policies.

1) Commercial General Liability: \$1,000,000 combined single limit per occurrence for bodily injury, personal injury, property damage, contractual liability and products /completed operations.

2) Automobile Liability and Physical Damage Coverage: \$500,000 combined single limit per occurrence for any auto, including statutory uninsured/underinsured motorists' coverage and \$1,000 medical payments. Policy to include collision and comprehensive coverage for any auto used for the purpose of this contract.

3) Workers' Compensation:

Coverage A / Workers' Compensation: statutory limits as required by the Labor Code of the State of Arizona.

Coverage B / Employer's Liability: limits of \$100,000 each accident, \$500,000 disease/policy limit, \$100,000 disease/each employee.

If the Contractor decides not to procure workers' compensation in accordance with Arizona law, the Contractor agrees to comply with the Arizona Workers' Compensation Act's (Act) requirements for withdrawing from the provisions of the Act, including, but not limited to, filing the appropriate notice of withdrawal with the commissioner. The Contractor is wholly responsible for taking the actions necessary to withdraw from the provisions of the Act. In lieu of procuring workers' compensation insurance and providing the Town with proof thereof, the Contractor agrees to hold the Town of Guadalupe, their Town Council, officers, agents, officials, employees, servants, volunteers, contractors and representatives harmless from any and all suits, claims, and actions arising from personal injuries sustained by the Contractor or Contractor's employees during the course of the performance of this contract, however caused.



## 4) Crime &amp; Fidelity:

- Coverage A - \$1,000,000 Employee Theft
- Coverage B - \$1,000,000 Forgery & Alteration
- Coverage C - \$1,000,000 Theft of Monies & Securities
- Coverage D - \$1,000,000 Robbery & Safe Burglary

The Contractor shall provide that the bonding company name the Town of Guadalupe as Joint Loss Payee for purposes of this Contract.

1) Commercial General Liability: \$1,000,000 combined single limit per occurrence for bodily injury, personal injury, property damage, contractual liability and products /completed operations.

2) Automobile Liability and Physical Damage Coverage: \$500,000 combined single limit per occurrence for any auto, including statutory uninsured/underinsured motorists' coverage and \$1,000 medical payments. Policy to include collision and comprehensive coverage for any auto used for the purpose of this contract.

## 3) Workers' Compensation:

- Coverage A - Workers' Compensation: statutory limits as required by the Labor Code of the State of Arizona.
- Coverage B - Employer's Liability: limits of \$100,000 each accident, \$500,000 disease/policy limit, \$100,000 disease/each employee.

If the Contractor decides not to procure workers' compensation in accordance with Arizona law, the Contractor agrees to comply with the Arizona Workers' Compensation Act's (Act) requirements for withdrawing from the provisions of the Act, including, but not limited to, filing the appropriate notice of withdrawal with the commissioner. The Contractor is wholly responsible for taking the actions necessary to withdraw from the provisions of the Act. In lieu of procuring workers' compensation insurance and providing the Town with proof thereof, the Contractor agrees to hold the Town of Guadalupe, their Town Council, officers, agents, officials, employees, volunteers, contractors and representatives harmless from any and all suits, claims, and actions arising from personal injuries sustained by the Contractor or Contractor's employees during the course of the performance of this contract, however caused.

## 4) Crime &amp; Fidelity:

- Coverage A - \$1,000,000 Employee Theft
- Coverage B - \$1,000,000 Forgery & Alteration
- Coverage C - \$1,000,000 Theft of Monies & Securities
- Coverage D - \$1,000,000 Robbery & Safe Burglary

The Contractor shall provide that the bonding company name the Town of Guadalupe as Joint Loss Payee for purposes of this Contract.

5) Professional Liability: \$1,000,000 per occurrence, \$2,000,000 aggregate each claim.

6) Personal Property: "All risk" insurance on a replacement cost basis to cover the value of personal property belonging to the Contractor and others (including but not limited to the personal property of subcontractors) located on Town property while in use or in storage for the duration of the contract. Deductible not to exceed \$1,000. The Contractor agrees that the Town will not assume any responsibility for the Contractor's personal property.

B. Additional Insured Endorsement: All liability policies (with the exception of Worker's Compensation and Professional Liability) shall have the Town of Guadalupe, and the Town Council, agents, officials, employees, volunteers, boards and commissions endorsed as an Additional Insured with respect to liability arising out of or in connection with the activities performed by or on behalf of the Contractor; products and completed operations of the Contractor; premises owned, leased, or used by the Contractor; or automobiles owned, leased, hired or borrowed by the Contractor. The coverage shall contain no special limitations on the scope of protection afforded to the Town.

C. Acceptability of Insurers: Contractor's policies shall be written by insurance companies licensed to do business in the State of Arizona, with a Best's rating of no less than A:VII, or otherwise deemed acceptable by the Town Manager.

D. Subcontractors: Contractor shall include all subcontractors as insured under its policies or shall furnish separate certificates and endorsements for each subcontractor. All coverage for subcontractors shall be subject to all of the requirements stated herein.

E. Waiver of Subrogation: Contractor shall provide that all insurance policies include a waiver of subrogation clause that states that it is agreed that in no event shall the insurance company have any right of recovery against the Town. When the Contractor is self-insured, it is agreed that in no event shall the Contractor have any right of recovery against the Town.

F. Claims-Made Form: If the insurance coverage is underwritten on a claims-made basis, the retroactive date shall be prior to or coincide with the date of the contract. The certificate of insurance shall state the retroactive date and that the coverage is claims-made. The Contractor shall maintain coverage for the duration of the contract and for the two (2) years following the completion of the contract. Evidence of such coverage shall be provided to the Town thirty (30) days prior to each policy expiration.

G. Aggregate Limits: If a general aggregate is used, the general aggregate limit shall apply separately to the project or shall be twice the occurrence limit. All aggregate limits must be declared to the Town. It is agreed that the Contractor shall notify the Town with reasonable promptness with information concerning the erosion of limits due to claims paid under the general aggregate during the contract term. If the aggregate limit is eroded, the Contractor agrees to reinstate or purchase additional limits to meet the minimum limit requirements stated herein. The Contractor shall pay the premium.

H. Deductibles and Self-Insured Retentions: Contractor must declare any deductibles or self-insured retentions to the Town. All deductibles or self-insured retentions are the sole responsibility of the Contractor to pay and/or to indemnify.

I. Notice of Cancellation or Nonrenewal: For other than non-payment of premium, each insurance policy required by this exhibit shall be endorsed to state that coverage shall not be suspended, voided, cancelled, or reduced in coverage or in limits except after thirty (30) days prior written notice has been given to the Town. Ten (10) days prior written notice shall be given for non-payment of premium

J. Other Insurance Provisions: The policies are to contain, or be endorsed to contain, the following provisions:

1) Liability Coverage

The Contractor's insurance coverage shall be primary insurance with respect to the Town. Any insurance or self-insurance maintained by the Town shall be excess of the Contractor's insurance and shall not contribute with it.

Coverage shall state that the Contractor's insurance shall apply separately to each insured against whom a claim is made or suit is brought.

Any failure to comply with the claim reporting provisions of the policy shall not affect coverage provided to the Town.

K. Verification of Coverage: The Contractor shall provide the Town with certificates of insurance, declaration pages, policy endorsements or provisions confirming compliance with this exhibit before work commences. The certificates and endorsements for each insurance policy are to be signed by a person authorized by the insurer to bind coverage on its behalf. Renewal of expiring certificates shall be filed thirty (30) days prior to expiration. The Town reserves the right to require complete, certified copies of all required policies, at any time. All insurance documents required by this exhibit should be mailed to: Town of Guadalupe, Finance Officer, 9241 S. Avenida del Yaqui, Guadalupe, AZ 85283

L. Failure to Purchase or Maintain Insurance: If the Town or the Contractor is damaged by failure of the Contractor to purchase or maintain insurance required by this exhibit, the Contractor shall bear all reasonable costs including, but not limited to, attorney's fees and costs of litigation, properly attributable thereto.

**RESOLUTION NO. R2021.01**

A RESOLUTION OF THE TOWN OF GUADALUPE, ARIZONA, MAYOR AND COMMON COUNCIL, DESIGNATING THE TOWN MANAGER / CLERK AS THE CHIEF FISCAL OFFICER FOR OFFICIALLY SUBMITTING THE FISCAL YEAR 2022 EXPENDITURE LIMITATION REPORT TO THE ARIZONA AUDITOR GENERAL.

**WHEREAS**, A.R.S. §41-1279.07(E) requires each county, city, town, and community college district to annually provide to the Auditor General by July 31 the name of the Chief Fiscal Officer the governing body designated to officially submit the current year’s annual expenditure limitation report (AELR) on the governing body’s behalf; and

**WHEREAS**, the Town of Guadalupe, Mayor and Council desires to designate the Town Manager / Clerk, as the Town of Guadalupe Chief Fiscal Officer; and,

**WHEREAS**, Entities must submit an updated form and documentation for any changes in the individuals designated to file AELR.

**NOW THEREFORE, BE IT RESOLVED** that the Town Council of the Town of Guadalupe, Mayor and Council as follows:

**SECTION 1.** The recitals above are hereby incorporated as if fully set forth herein.

**SECTION 2.** The Town Manager / Clerk is hereby designated as the Town of Guadalupe’s Chief Fiscal Officer for purposes of submitting the fiscal year 2022 AELR to the Arizona Auditor General’s Office on the governing body’s behalf.

**PASSED AND ADOPTED** by the Mayor and Council of the Town of Guadalupe, Arizona, this 25<sup>th</sup> day of February, 2021.

**Attested to:**

\_\_\_\_\_  
Valerie Molina, Mayor  
Town of Guadalupe

\_\_\_\_\_  
Jeff Kulaga, Town Manager /Clerk  
Town of Guadalupe

**Reviewed by:**

**Approved as to form:**

\_\_\_\_\_  
Robert Thaxton, Finance Director  
Town of Guadalupe

\_\_\_\_\_  
David E. Ledyard, Town Attorney  
Town of Guadalupe

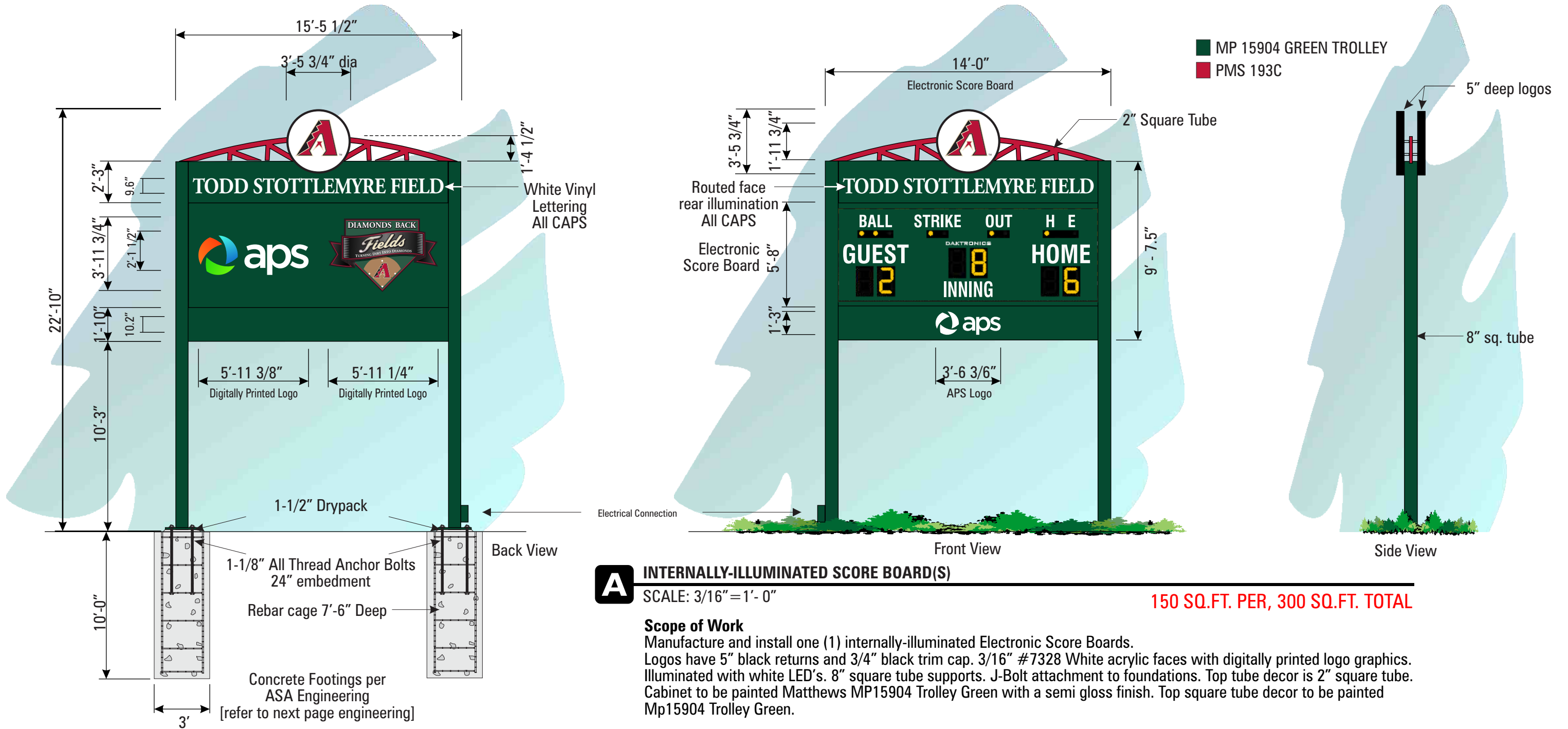

**A INTERNALLY-ILLUMINATED SCORE BOARD(S)**

SCALE: 3/16" = 1' - 0"

150 SQ.FT. PER, 300 SQ.FT. TOTAL

**Scope of Work**

Manufacture and install one (1) internally-illuminated Electronic Score Boards. Logos have 5" black returns and 3/4" black trim cap. 3/16" #7328 White acrylic faces with digitally printed logo graphics. Illuminated with white LED's. 8" square tube supports. J-Bolt attachment to foundations. Top tube decor is 2" square tube. Cabinet to be painted Matthews MP15904 Trolley Green with a semi gloss finish. Top square tube decor to be painted Mp15904 Trolley Green.

\*\*\* Remove existing scoreboard, cut mounting bolts at ground level, move sign over enough for new foundations to be poured.

THIS DRAWING IS THE INTELLECTUAL PROPERTY OF ARIZONA COMMERCIAL SIGNS. REPRODUCTION IS PROHIBITED BY LAW - STATUTE: 17 U.S.C. §§ 101-810

www.arizonacommercialsigns.com



PROJECT NAME:

■ PIMMEX CONTRACTING - ARIZONA DIAMONDBACKS  
TODD STOTTMLEYRE FIELD  
5424 EAST CALLE CERRITOS  
GUADALUPE, ARIZONA 85283  
CONTACT: BRYAN DOOLEN  
PHONE: (602) 616-2214  
EMAIL: BRYAN@PIMMEXCONTRACTING.COM



CONTACT REP:

■ FRED SULLENBERGER - (c) 623-215-5591

DESIGNER:

■ CHRIS HEARN - (d) 480-663-2087

DESIGN NUMBER:

■ PIMMEX - TODD STOTTMLEYRE FIELD - DBACKS - 041520 - RO PRO

SCALE:

■ AS NOTATED

DATE:

■ 11/09/2020 10:48 AM MST

REVISIONS:

1	
2	
3	
4	
5	

LANDLORD / DEVELOPER APPROVAL  
SIGNATURE & DATE:

CUSTOMER APPROVAL  
SIGNATURE & DATE:

SHEET:

1 OF 4  
PRODUCTION

Bingham Engineering Consultants, PLLC

PROJECT: 20-0251

Location: 5424 East Calle Cerritos, Guadalupe, AZ

CODE: 2019 IBC  
WIND: 35 MPH, EXPOSURE: C

MATERIALS:  
CONCRETE: 2800 PSI  
REINFORCING STEEL: ASTM A-601, GRADE 40, #4 AND SMALLER  
ANCHOR BOLTS: ASTM A-307, GRADE 50, 3/4" AND LARGER  
ANCHOR BOLTS: ASTM A-307, GRADE 50, 3/4" AND LARGER  
SPECIAL NOTES: FOR ALL HULL WELLS  
ALL MEASUREMENTS TO BE FIELD VERIFIED

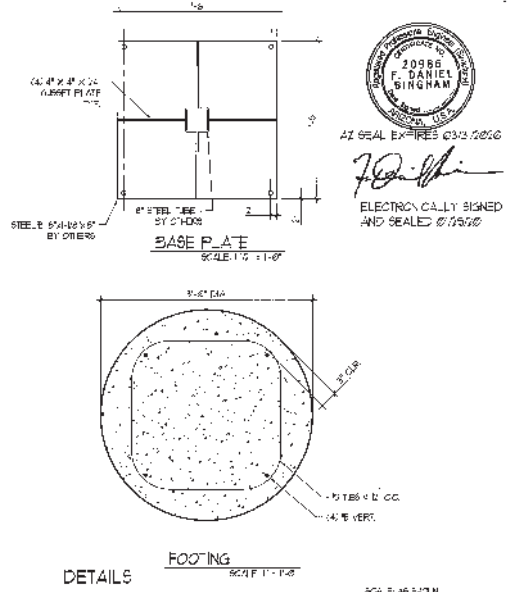
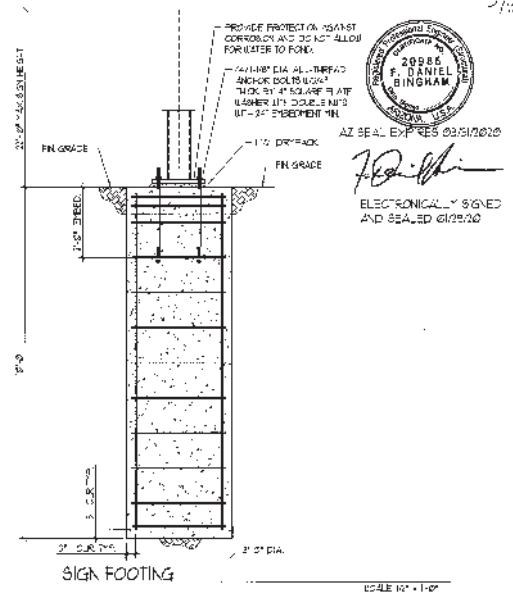

BUILDING CODE: 2019 IBC

WIND: 35 MPH, EXPOSURE: C, IMPORTANCE FACTOR: 1

MATERIAL SPECIFICATIONS AND NOTES:  
CONCRETE: 2800 PSI, 4" MIN. THICK  
REINFORCING STEEL: ASTM A-601, GRADE 40, #4 AND LARGER  
ANCHOR BOLTS: ASTM A-307, GRADE 50, 3/4" AND LARGER  
BASE PLATE: STEEL, BY OTHERS

PROVIDE PROTECTION TO PREVENT CORROSION FROM SOIL OR ALLOW FOR WATER TO FLOW UNDER FOOTING TO BE UNDERSLABBED AND WELL DRAINED. MAXIMUM SIZE OF AGGREGATE SHALL BE 1/4" DIA PER ASTM C-633 FOR PORTLAND CEMENT SHALL CONFORM TO ASTM C-150, TYPE I. NO MORE THAN 30 MINUTES SHALL ELAPSE BETWEEN CONCRETE BATCHING AND CONCRETE PLACEMENT. ALL APPROVED BY TESTING AGENCY.

ALL CONSTRUCTION AND WORKMANSHIP SHALL CONFORM TO THE CURRENT BUILDING CODE. CONTRACTOR MUST CHECK ALL DIMENSIONS, FINISH CONDITIONS, AND SITE CONDITIONS BEFORE STARTING WORK. ARCHITECT/ENGINEER SHALL BE NOTIFIED IMMEDIATELY OF ANY DISCREPANCIES OR POSSIBLE DEFICIENCIES.

THE DRAWINGS AND SPECIFICATIONS REPRESENT THE INTENDED STRUCTURE. ALL BRACING, TEMPORARY SUPPORTS, SHORING, ETC. IS THE SOLE RESPONSIBILITY OF THE CONTRACTOR.

OBSERVATION VISITS TO THE JOB SITE BY THE ARCHITECT/ENGINEER DO NOT INCLUDE INSPECTION OF CONSTRUCTION PROCEDURES. THE CONTRACTOR IS SOLELY RESPONSIBLE FOR ALL CONSTRUCTION METHODS AND CONDITIONS AT THE WORKSITE. THESE VISITS WILL NOT BE CONSIDERED AS CONTINUOUS AND DETAILED INSPECTIONS.

MATERIAL SPECIFICATIONS AND NOTES

DATE DESIGNED	DATE FOR CONSTRUCTION	PROJECT NAME	SCALE
11/09/2020	AS NOTED	5424 EAST CALLE CERRITOS, GUADALUPE, AZ	AS NOTED

DATE DESIGNED	DATE FOR CONSTRUCTION	PROJECT NAME	SCALE
11/09/2020	AS NOTED	5424 EAST CALLE CERRITOS, GUADALUPE, AZ	AS NOTED

DATE DESIGNED	DATE FOR CONSTRUCTION	PROJECT NAME	SCALE
11/09/2020	AS NOTED	5424 EAST CALLE CERRITOS, GUADALUPE, AZ	AS NOTED

Bingham Engineering Consultants, PLLC

Client: AZ COMMERCIAL SIGNS  
Project: 5424 East Calle Cerritos, Guadalupe, AZ

WIND ANALYSIS SIGN

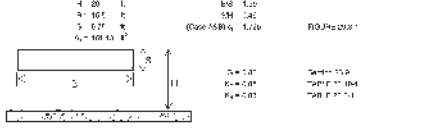

WIND DIRECTION	WIND SPEED (MPH)	WIND PRESSURE (PSF)
0-90	35	15.00
90-180	35	15.00
180-270	35	15.00
270-360	35	15.00

Bingham Engineering Consultants, PLLC

Client: AZ COMMERCIAL SIGNS  
Project: 5424 East Calle Cerritos, Guadalupe, AZ

ULTRACAPACITY FOOTING AND SOIL

ULTRACAPACITY FOOTING AND SOIL
ULTRACAPACITY FOOTING AND SOIL

ULTRACAPACITY FOOTING AND SOIL
ULTRACAPACITY FOOTING AND SOIL

SIMPSON Anchor Designer Software

ANCHOR DESIGNER SOFTWARE
ANCHOR DESIGNER SOFTWARE

ANCHOR DESIGNER SOFTWARE
ANCHOR DESIGNER SOFTWARE

SIMPSON Anchor Designer Software

ANCHOR DESIGNER SOFTWARE
ANCHOR DESIGNER SOFTWARE

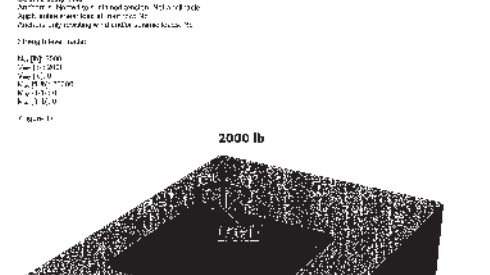

SIMPSON Anchor Designer Software

ANCHOR DESIGNER SOFTWARE
ANCHOR DESIGNER SOFTWARE

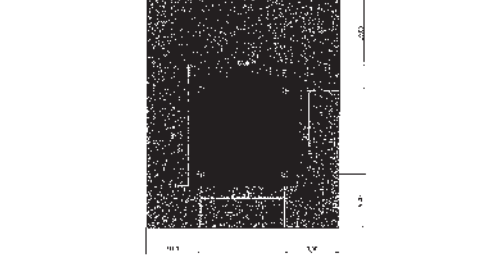

THIS DRAWING IS THE INTELLECTUAL PROPERTY OF ARIZONA COMMERCIAL SIGNS. REPRODUCTION IS PROHIBITED BY LAW - STATUTE: 17 U.S.C. §§ 101-810

www.arizonacommercialsigns.com

Nationwide Sign Systems  
ARIZONA COMMERCIAL SIGNS  
4018 E. WINSLOW • PHOENIX AZ 85040  
OFFICE: (480) 921-9900 • FAX: (602) 437-8073

PROJECT NAME:  
**PIMMEX CONTRACTING - ARIZONA DIAMONDBACKS**  
**TODD STOTTLEMYRE FIELD**  
 5424 EAST CALLE CERRITOS  
 GUADALUPE, ARIZONA 85283  
 CONTACT: BRYAN DOOLEN  
 PHONE: (602) 616-2214  
 EMAIL: BRYAN@PIMMEXCONTRACTING.COM

CONTACT REP:  
**FRED SULLENBERGER - (c) 623-215-5591**

DESIGNER:  
**CHRIS HEARN - (d) 480-663-2087**

DESIGN NUMBER:  
**PIMMEX - TODD STOTTLEMYRE FIELD - DBACKS - 041520 - RO PRO**

SCALE:  
**AS NOTATED**

DATE:  
**11/09/2020 10:48 AM MST**

REVISIONS:

- 1
- 2
- 3
- 4
- 5

LANDLORD / DEVELOPER APPROVAL  
SIGNATURE & DATE:

CUSTOMER APPROVAL  
SIGNATURE & DATE:

SHEET:  
**2 OF 4**  
**PRODUCTION**

<b>SIMPSON</b>	Anchor Designer™	Version 11.0.0.0
Software	File	Page 42
Project Name	Project	
Project Path	Project	
Project Date	Project	
Project User	Project	
Project Email	Project	

3. Resulting Anchor Forces			
Anchor	Force (k)	Direction	Notes
1	10.00	Vertical	
2	10.00	Vertical	
3	10.00	Vertical	
4	10.00	Vertical	

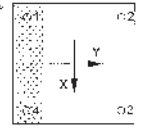

4. Steel Strength of Anchor in Tension (Sec. 17.4.1)			
Anchor	Area (in²)	Strength (k)	Notes
1	0.31	20.00	

5. Concrete Development Strength of Anchor in Tension (Sec. 17.4.2)			
Anchor	Area (in²)	Strength (k)	Notes
1	0.31	15.00	

6. Pullout Strength of Anchor in Tension (Sec. 17.4.3)			
Anchor	Area (in²)	Strength (k)	Notes
1	0.31	15.00	

Final design results must be checked by a qualified professional engineer. This drawing is for informational purposes only. It is not to be used for construction without the approval of the engineer of record.

<b>SIMPSON</b>	Anchor Designer™	Version 11.0.0.0
Software	File	Page 43
Project Name	Project	
Project Path	Project	
Project Date	Project	
Project User	Project	
Project Email	Project	

7. Steel Plate Development Strength of Anchor in Tension (Sec. 17.4.4)			
Anchor	Area (in²)	Strength (k)	Notes
1	0.31	20.00	

8. Concrete Breakout Strength of Anchor in Tension (Sec. 17.4.5)			
Anchor	Area (in²)	Strength (k)	Notes
1	0.31	15.00	

9. Steel Strength of Anchor in Tension (Sec. 17.4.1)			
Anchor	Area (in²)	Strength (k)	Notes
1	0.31	20.00	

10. Concrete Development Strength of Anchor in Tension (Sec. 17.4.2)			
Anchor	Area (in²)	Strength (k)	Notes
1	0.31	15.00	

11. Pullout Strength of Anchor in Tension (Sec. 17.4.3)			
Anchor	Area (in²)	Strength (k)	Notes
1	0.31	15.00	

11. Results			
Anchor	Area (in²)	Strength (k)	Notes
1	0.31	15.00	

Final design results must be checked by a qualified professional engineer. This drawing is for informational purposes only. It is not to be used for construction without the approval of the engineer of record.

<b>SIMPSON</b>	Anchor Designer™	Version 11.0.0.0
Software	File	Page 44
Project Name	Project	
Project Path	Project	
Project Date	Project	
Project User	Project	
Project Email	Project	

12. Summary			
Anchor	Area (in²)	Strength (k)	Notes
1	0.31	15.00	

13. Summary			
Anchor	Area (in²)	Strength (k)	Notes
1	0.31	15.00	

14. Summary			
Anchor	Area (in²)	Strength (k)	Notes
1	0.31	15.00	

15. Summary			
Anchor	Area (in²)	Strength (k)	Notes
1	0.31	15.00	

16. Summary			
Anchor	Area (in²)	Strength (k)	Notes
1	0.31	15.00	

17. Summary			
Anchor	Area (in²)	Strength (k)	Notes
1	0.31	15.00	

Final design results must be checked by a qualified professional engineer. This drawing is for informational purposes only. It is not to be used for construction without the approval of the engineer of record.

**Boards utilize this controller instead of the standard controller.**

RC-200 Wireless Hand-Held Controller



**EXISTING BOARD**

**THIS DRAWING IS THE INTELLECTUAL PROPERTY OF ARIZONA COMMERCIAL SIGNS. REPRODUCTION IS PROHIBITED BY LAW - STATUTE: 17 U.S.C. §§ 101-810**

**www.arizonacommercialsigns.com**

Nationwide Sign Systems  
ARIZONA COMMERCIAL SIGNS  
4018 E. WINSLOW • PHOENIX AZ 85040  
OFFICE: (480) 921-9900 • FAX: (602) 437-8073

PROJECT NAME:

- PIMMEX CONTRACTING - ARIZONA DIAMONDBACKS
- TODD STOTTELMYRE FIELD
- 5424 EAST CALLE CERRITOS
- GUADALUPE, ARIZONA 85283
- CONTACT: BRYAN DOOLEN
- PHONE: (602) 616-2214
- EMAIL: BRYAN@PIMMEXCONTRACTING.COM

CONTACT REP:

- FRED SULLENBERGER - (c) 623-215-5591

DESIGNER:

- CHRIS HEARN - (d) 480-663-2087

DESIGN NUMBER:

- PIMMEX - TODD STOTTELMYRE FIELD - DBACKS - 041520 - RO PRO

SCALE:

- AS NOTATED

DATE:

- 11/09/2020 10:48 AM MST

REVISIONS:

1	
2	
3	
4	
5	

LANDLORD / DEVELOPER APPROVAL SIGNATURE & DATE:

CUSTOMER APPROVAL SIGNATURE & DATE:

SHEET:

**3** OF **4**

**PRODUCTION**

**PROJECT PERMIT INFORMATION:**

PROJECT ADDRESS:  
 ■ 5424 EAST CALLE CERRITOS  
 GUADALUPE, ARIZONA 85283

DEED NUMBER:  
 ■ 031454998

ARIZONA PARCEL NUMBER (APN):  
 ■ 301-10-008M

PROPERTY ZONING:  
 ■ C-MIX

PARCEL USE CODE (PUC):  
 ■ 9750

LOT SIZE (SQ.FT.):  
 ■ 137,827

JURISDICTION:  
 ■ TOWN OF GUADALUPE - MARICOPA COUNTY



**PROJECT DETAILS:**

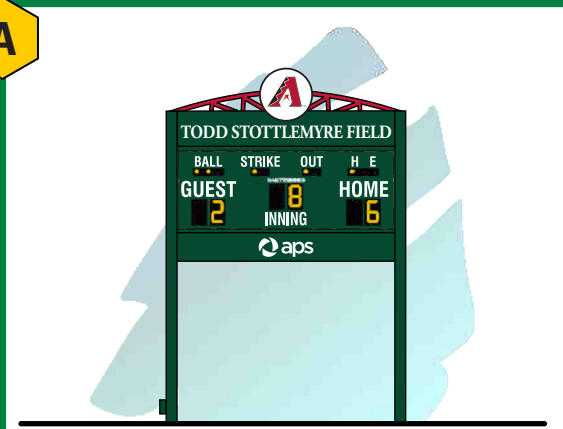

**PROJECT NOTES:**

Blank lines for project notes.

**NEW FOOTING/PILE FOR NEW SCOREBOARD INSTALL SHIFT TO LEFT WHEN LOOKING AT SIGN FROM OLD LOCATION OF SCOREBOARD**



**SITE PLAN**

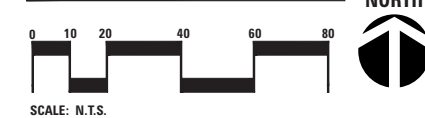

THIS DRAWING IS THE INTELLECTUAL PROPERTY OF ARIZONA COMMERCIAL SIGNS. REPRODUCTION IS PROHIBITED BY LAW - STATUTE: 17 U.S.C. §§ 101-810

www.arizonacommercialsigns.com



PROJECT NAME:  
 ■ PIMMEX CONTRACTING - ARIZONA DIAMONDBACKS  
 TODD STOTTMLEYRE FIELD  
 5424 EAST CALLE CERRITOS  
 GUADALUPE, ARIZONA 85283  
 CONTACT: BRYAN DOOLEN  
 PHONE: (602) 616-2214  
 EMAIL: BRYAN@PIMMEXCONTRACTING.COM



CONTACT REP:  
 ■ FRED SULLENBERGER - (c) 623-215-5591

DESIGNER:  
 ■ CHRIS HEARN - (d) 480-663-2087

DESIGN NUMBER:  
 ■ PIMMEX - TODD STOTTMLEYRE FIELD - DBACKS - 041520 - RO PRO

SCALE:  
 ■ AS NOTATED

DATE:  
 ■ 11/09/2020 10:48 AM MST

REVISIONS:

1	
2	
3	
4	
5	

LANDLORD / DEVELOPER APPROVAL  
 SIGNATURE & DATE:

CUSTOMER APPROVAL  
 SIGNATURE & DATE:

SHEET:  
**4** OF **4**  
 PRODUCTION